

# Steinmeyer Mechatronik GmbH

## Precision Stages and Systems or Vacuum

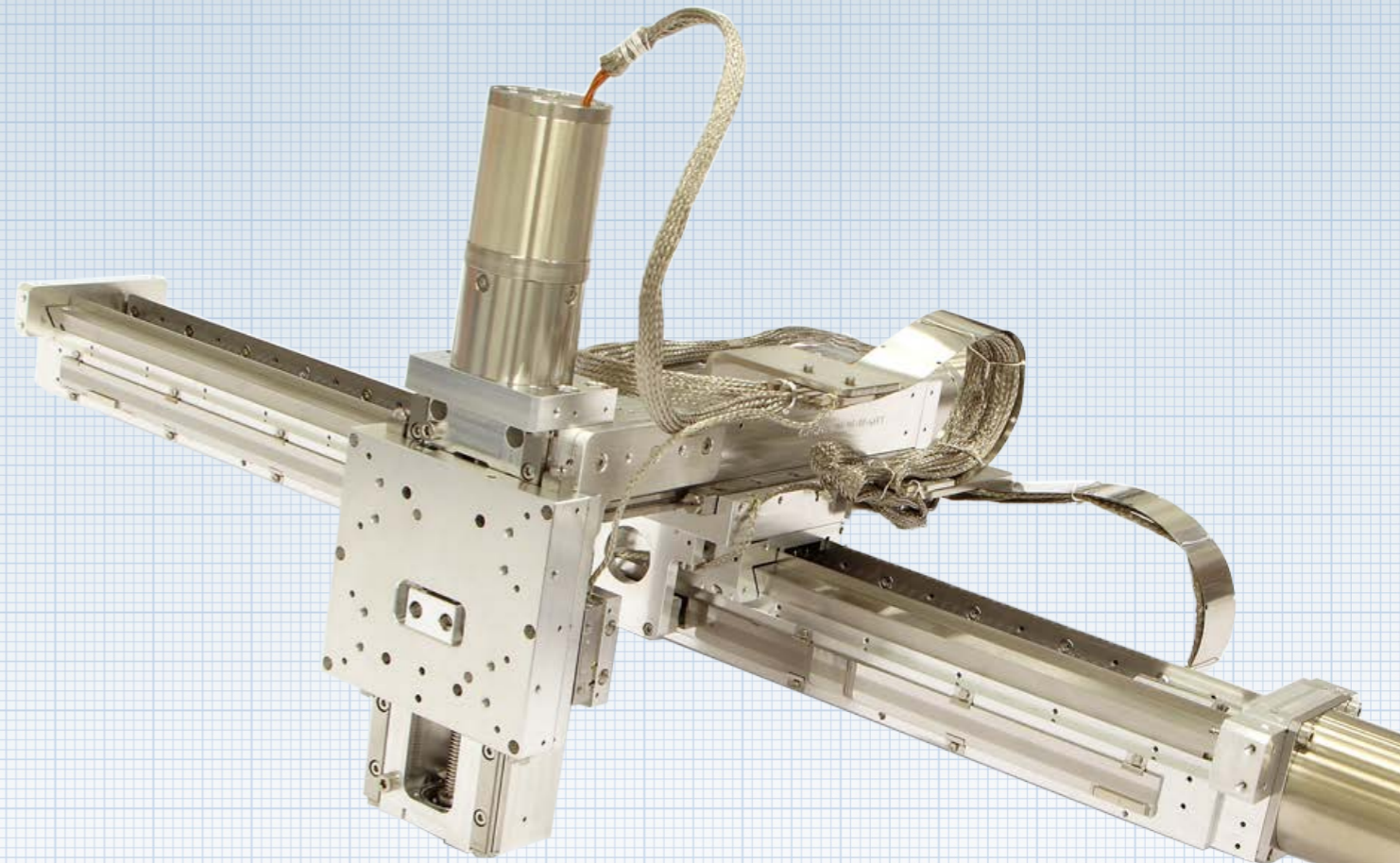

## The Steinmeyer Group

- Three Competence Centers. Worldwide over 650 employees.
- High-precision ball screws for industrial applications and aerospace
- High-precision positioning solutions
- High-precision metrology
- Facilities in Germany and the USA

## Steinmeyer Mechatronik GmbH

- Competence center for positioning solutions and mechatronic systems
- 100 highly motivated and special skilled employees in Dresden
- Over 140 years experience in mechanical design and production
- Innovative designs for a variety of applications
- Three shift operation in production

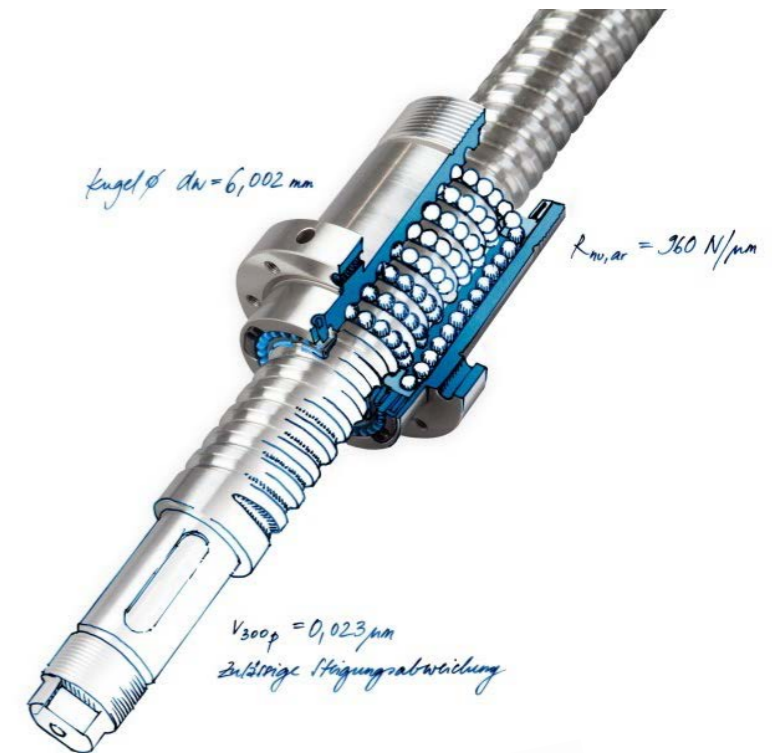

## What are we offering?

- **Stages, Assemblies, Systems**

Catalogue Stages, Custom Designs

- **OEM Design and Manufacturing**

We design, manufacture and test mechatronic assemblies for a wide variety of applications.

- **All-in-one Process**

We carry out the whole design and production process under one roof in our factory in Dresden, Germany.

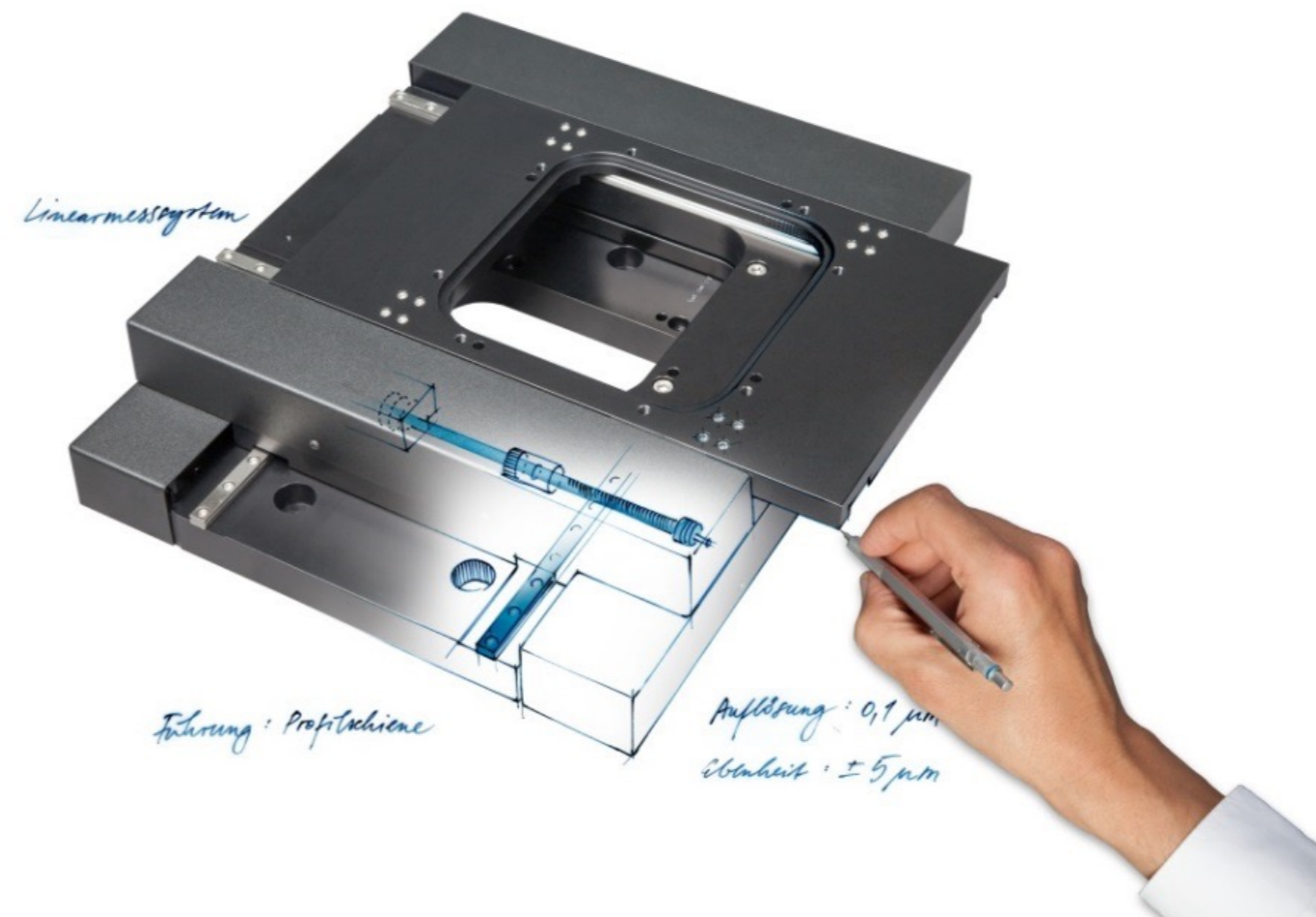



Assembly and test in our Clean Room

## Vacuum Systems and Stages



# Vacuum Linear Stages

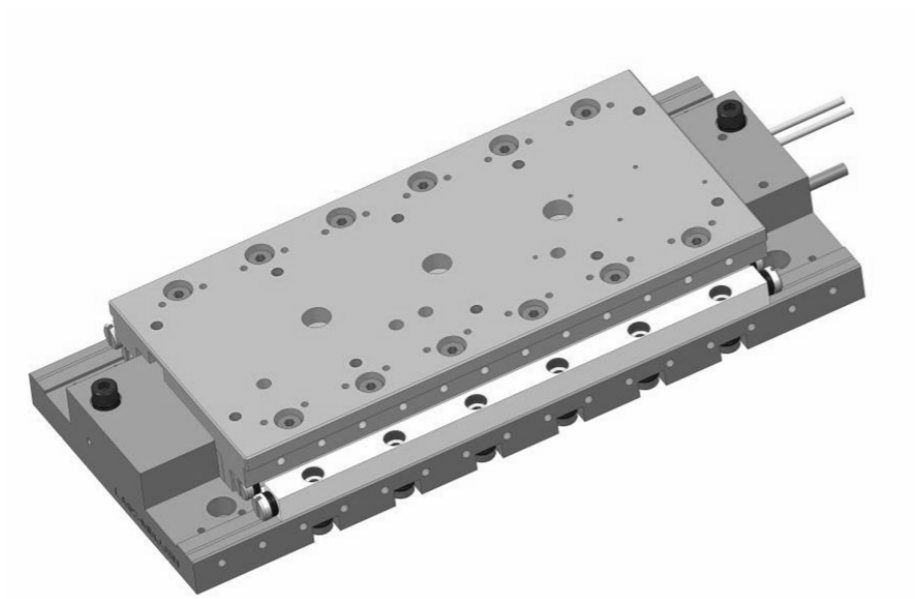

**Application:** scanning of samples

**Benefit:** fast positioning in UHV, also vertically

**Features:** positioning with extreme resolution, very slim, with internal motor, magnet free

- Vacuum: all pressure ranges HV / UHV down to  $10^{-11}$  mbar
- Magnetism: magnetic / low magnetic / magnet free
- Lubrication: liquid down to  $10^{-8}$  mbar / dry lube down to  $10^{-11}$  mbar
- max. bake-out temperature: 120 °C

### **Technical Data**

- Stroke: 40 mm
- Repeatability:  $\pm 0,4 \mu\text{m}$
- Load: 2 kg horizontally, 1 kg vertically
- Velocity: 100 mm/s

### **Components**

- Motor: Nanomotion
- Feedback: Linear 5 nm...100 nm
- Guide: Cross Roller Stainless Steel, Hybrid, optionally Ceramics
- Controller: Galil



**Application:** fast transport stage

**Benefit:** high life time despite dry lube

**Features:** dry lube ball screw drive

- Vacuum: all pressure ranges HV / UHV down to  $10^{-11}$  mbar
- Magnetism: magnetic
- Lubrication: liquid down to  $10^{-8}$  mbar / dry lube down to  $10^{-11}$  mbar
- max. bake-out temperature: 120 °C

### **Technical Data**

- Stroke: 100 mm, 200 mm, 500 mm
- Repeatability:  $\pm 4 \mu\text{m}$  SM, with Feedback  $\pm 0,5 \mu\text{m}$
- Load: 5 kg horizontally, 1 kg vertically
- Velocity: 100 mm/s

### **Components**

- Motor: Stepper Motor
- Feedback: Linear 100 nm
- Guide: Stainless Steel Hybrid Recirculating Ball Guides
- Controller: FMC2, Galil

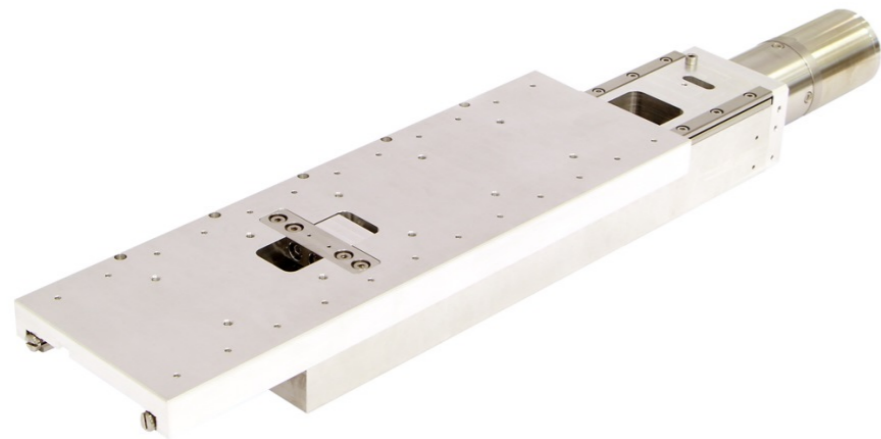
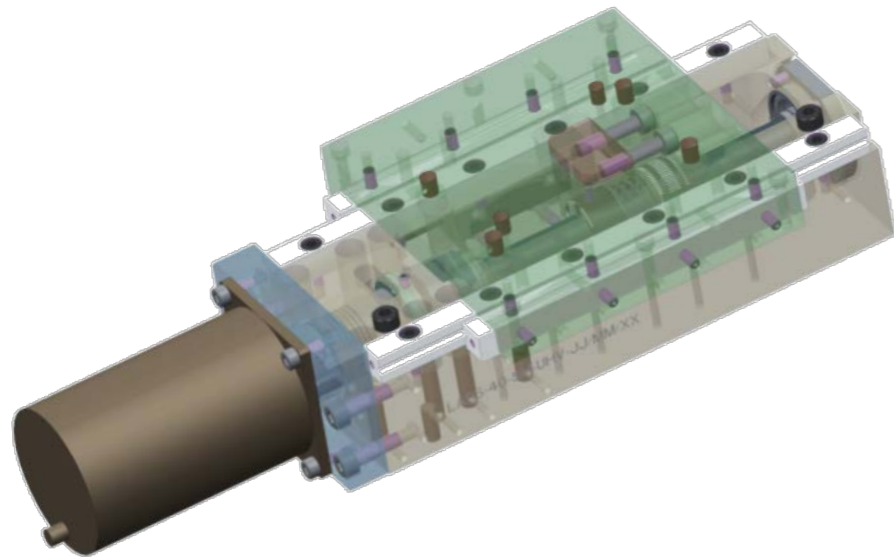

Extra Long Version

**Application:** transport stage, scanning stage

**Benefit:** high life time despite dry lube

**Features:** lead screw with dry lube or ball screw with liquid lube

- Vacuum: all pressure ranges HV / UHV down to  $10^{-11}$  mbar
- Magnetism: magnetic
- Lubrication: liquid down to  $10^{-8}$  mbar / dry lube down to  $10^{-11}$  mbar
- max. bake-out temperature: 120 °C

### **Technical Data**

- Stroke: 5 mm, 10 mm, 40 mm, 80 mm
- Repeatability:  $\pm 4 \mu\text{m}$  SM, with Feedback  $\pm 0,5 \mu\text{m}$
- Load: 4,5 kg horizontally or vertically
- Velocity: 5 mm/s

### **Components**

- Motor: Stepper Motor
- Feedback: Open Loop or Linear Scale 100 nm
- Guide: Cross Roller Stainless Steel, Hybrid
- Controller: FMC, Galil





Version with Extra Width

**Application:** transport stage, scanning stage for high loads

**Benefit:** high life time despite dry lube

**Features:** lead screw with dry lube or ball screw with liquid lube

- Vacuum: all pressure ranges HV / UHV down to  $10^{-11}$  mbar
- Magnetism: magnetic
- Lubrication: liquid down to  $10^{-8}$  mbar / dry lube down to  $10^{-11}$  mbar
- max. bake-out temperature: 120 °C

### **Technical Data**

- Stroke: 5 mm, 10 mm, 40 mm, 80 mm
- Repeatability:  $\pm 4 \mu\text{m}$  SM, with Feedback  $\pm 0,5 \mu\text{m}$
- Load: 20 kg horizontally or vertically
- Velocity: 5 mm/s

### **Components**

- Motor: Stepper Motor
- Feedback: Open Loop or Linear Scale 100 nm
- Guide: Cross Roller Stainless Steel, Hybrid
- Controller: FMC, Galil

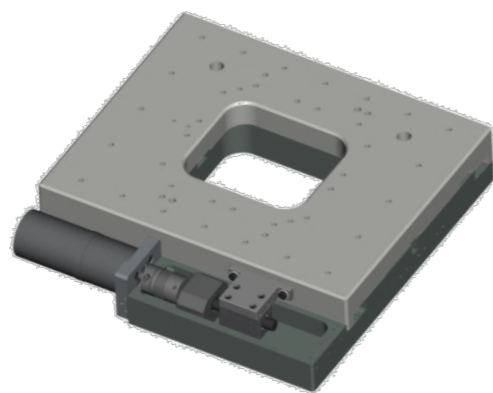
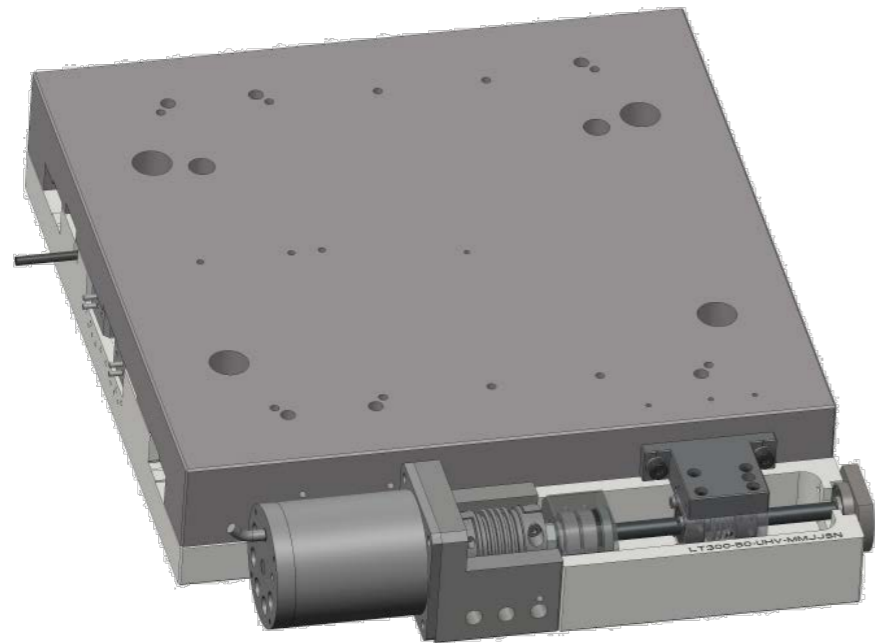

Version with Aperture

**Application:** transport stage, scanning stage for high loads

**Benefit:** high life time despite dry lube

**Features:** lead screw with dry lube or, ball screw with liquid piezo brakes for nm-stability

- Vacuum: all pressure ranges HV / UHV down to  $10^{-11}$  mbar
- Magnetism: magnetic
- Lubrication: liquid down to  $10^{-8}$  mbar / dry lube down to  $10^{-11}$  mbar
- max. bake-out temperature: 120 °C

### **Technical Data**

- Stroke: 10 mm, 50 mm, 100 mm
- Repeatability:  $\pm 4 \mu\text{m}$  SM, with Feedback  $\pm 0,5 \mu\text{m}$
- Load: 10 kg horizontally, 2 kg vertically
- Velocity: 5 mm/s

### **Components**

- Motor: Stepper Motor
- Feedback: Open Loop or Linear Scale 100 nm
- Guide: Cross Roller Stainless Steel, Hybrid
- Controller: FMC2, Galil

# Micro Stage MT170-NM/PM

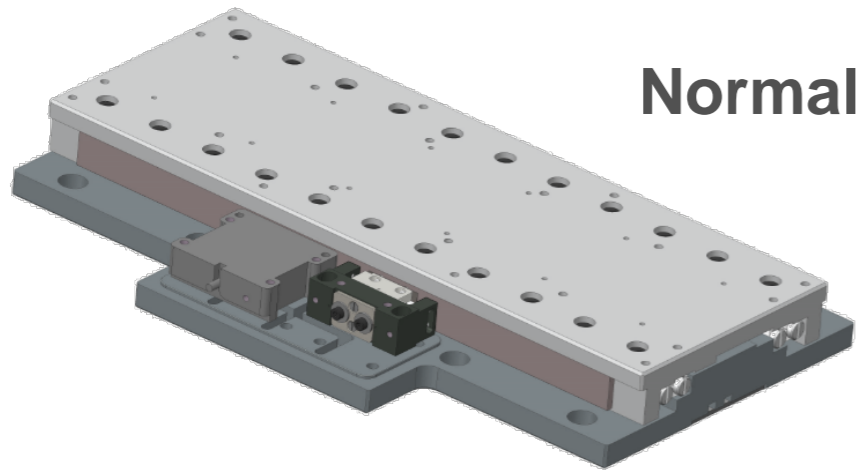

**Normal**

Optionally Piezo Motor or Nanomotion

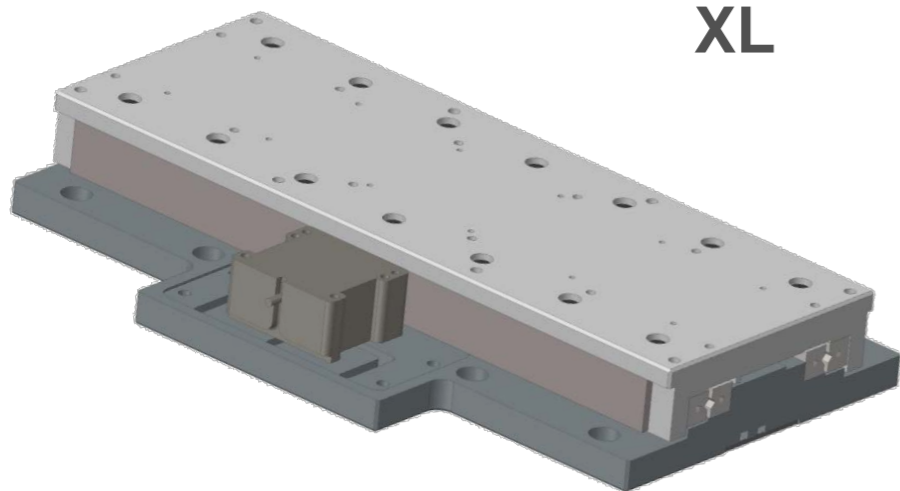

**XL**

Optionally, Single or Double Motorisation

**Application:** scanning of samples

**Benefit:** fast positioning in UHV, also vertically

**Features:** positioning with extreme resolution,

- Vacuum: all pressure ranges HV / UHV down to  $10^{-11}$  mbar
- Magnetism: magnetic / low magnetic / magnet free
- Lubrication: liquid down to  $10^{-8}$  mbar / dry lube down to  $10^{-11}$  mbar
- max. bake-out temperature: 120 °C

**Technical Data**

- Stroke: 200 mm
- Repeatability:  $\pm 0,4 \mu\text{m}$  NM,  $\pm 0,1 \mu\text{m}$  PM
- Load: 5 kg Normal, 10 kg XL (horizontally or vertically)
- Velocity: 5 mm/s PM or 100 mm/s NM

**Components**

- Motor: Nanomotion to 100 mm/s and Piezo Motor to 5 mm/s
- Feedback: Linear 5 nm...100 nm
- Guide: Cross Roller Stainless Steel, Hybrid, optionally Ceramics
- Controller: Galil

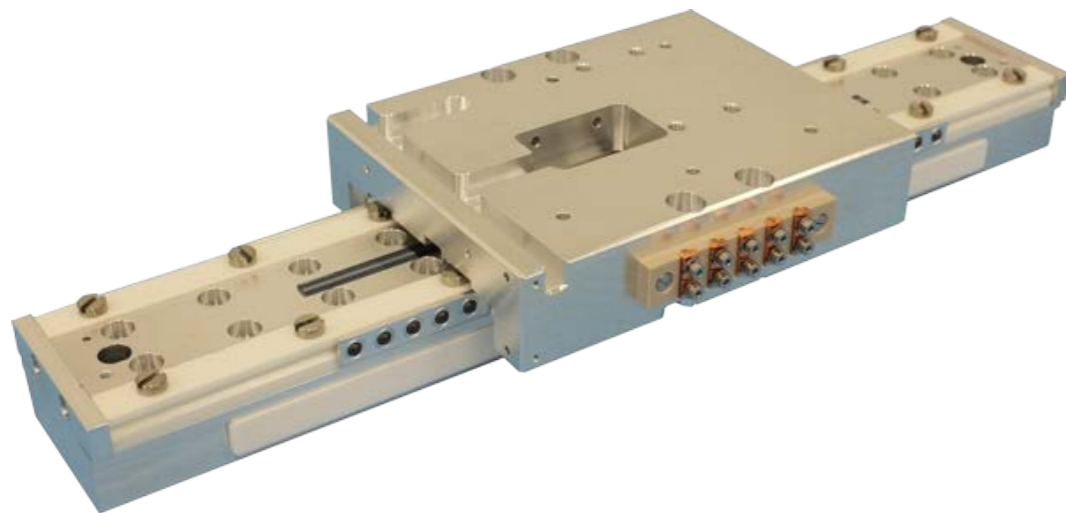

**Application:** scanning of samples

**Benefit:** Nanometer-positioning, also vertically

**Features:** positioning with extreme resolution and highest stiffness; Can be equipped with 2 (or 4) motors.

- Vacuum: all pressure ranges HV / UHV down to  $10^{-11}$  mbar
- Magnetism: magnetic / low magnetic / magnet free
- Lubrication: liquid down to  $10^{-8}$  mbar / dry lube down to  $10^{-11}$  mbar
- max. bake-out temperature: 120 °C

### **Technical Data**

- Stroke: 100 mm, 200 mm, 300 mm
- Repeatability:  $\pm 20$  nm
- Load: 5 (10)kg horizontally, 2 (4)kg vertically
- Velocity: 5 mm/s

### **Components**

- Motor: Piezo Motor
- Feedback: Linear 1 nm...100 nm
- Guide: Cross Roller Stainless Steel, Hybrid, optionally Ceramics
- Controller: Galil

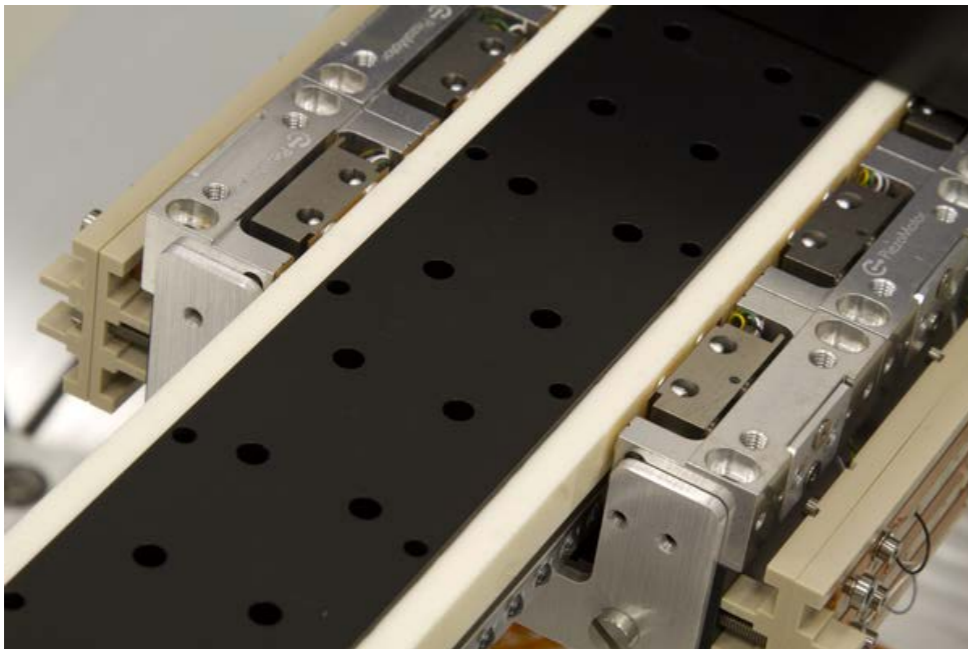
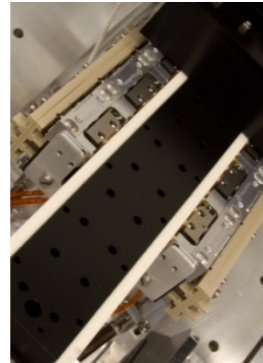
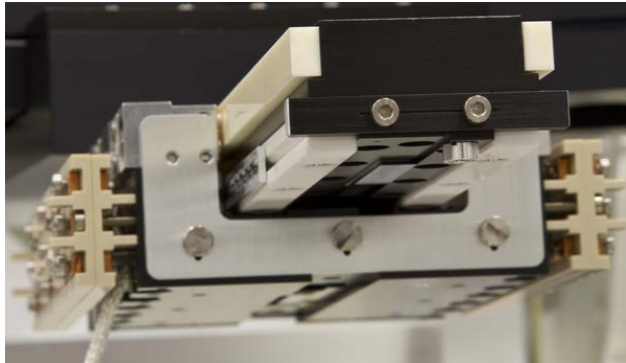

**Application:** scanning of samples

**Benefit:** nanometer-positioning, also vertically

**Features:** positioning with extreme resolution and highest stiffness; Can be equipped with 2, 4 (or 6) motors.

- Vacuum: all pressure ranges HV / UHV down to  $10^{-11}$  mbar
- Magnetism: magnetic / low magnetic / magnet free
- Lubrication: liquid down to  $10^{-8}$  mbar / dry lube down to  $10^{-11}$  mbar
- max. bake-out temperature: 120 °C

### **Technical Data**

- Stroke: max. 300 mm
- Repeatability:  $\pm 20$  nm
- Load: max. 10 (20)kg horizontally, 4 (10)kg vertically
- Velocity: 5 mm/s

### **Components**

- Motor: Piezo Motor
- Feedback: Linear 1 nm...100 nm
- Guide: Cross Roller Stainless Steel, Hybrid, optionally Ceramics
- Controller: Galil

# Vacuum Micro Stages

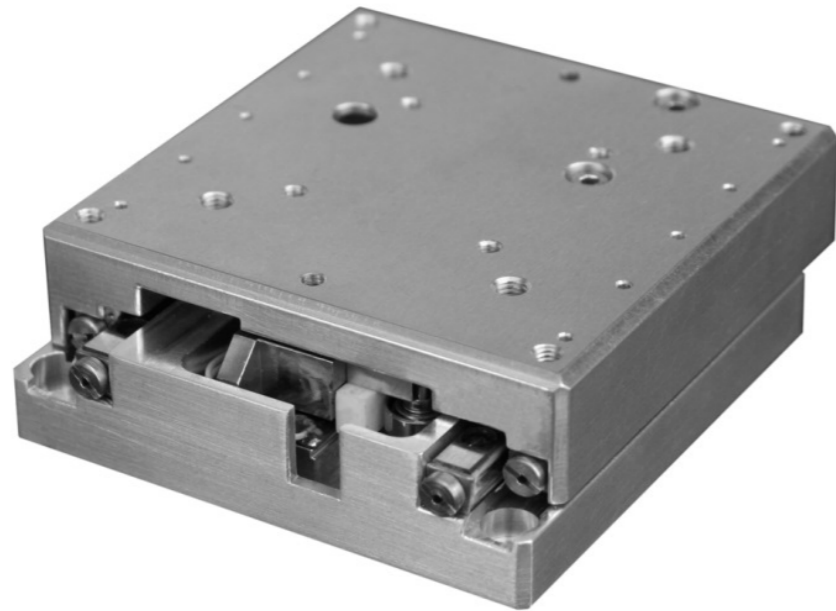

**Application:** multi purpose micro stage

**Benefit:** for high resolution scanning

**Features:** positioning with very high resolution

- Vacuum: all pressure ranges HV / UHV down to  $10^{-11}$  mbar
- Magnetism: magnetic / low magnetic / magnet free
- Lubrication: liquid down to  $10^{-8}$  mbar / dry lube down to  $10^{-11}$  mbar
- max. bake-out temperature: 120 °C

#### **Technical Data**

- Stroke: 10 mm
- Repeatability:  $\pm 0,1 \mu\text{m}$
- Load: 0,9 kg horizontally, 0,2 kg vertically
- Velocity: 5 mm/s

#### **Components**

- Motor: Piezo Motor
- Feedback: Linear 5 nm...100 nm
- Guide: Cross Roller Stainless Steel, Hybrid, optionally Ceramics
- Controller: Galil

**Application:** multi purpose micro stage

**Benefit:** for high resolution scanning

**Features:** positioning with very high resolution

- Vacuum: all pressure ranges HV / UHV down to  $10^{-11}$  mbar
- Magnetism: magnetic / low magnetic / magnet free
- Lubrication: liquid down to  $10^{-8}$  mbar / dry lube down to  $10^{-11}$  mbar
- max. bake-out temperature: 120 °C

### **Technical Data**

- Stroke: 20 mm, 50 mm, 100 mm
- Repeatability:  $\pm 0,4 \mu\text{m}$  NM,  $\pm 0,1 \mu\text{m}$  PM
- Load: 2 kg horizontally or vertically
- Velocity: 5 mm/s PM or 50 mm/s NM

### **Components**

- Motor: Piezo Motor / Nanomotion
- Feedback: Linear 5 nm...100 nm
- Guide: Cross Roller Stainless Steel, Hybrid, optionally Ceramics
- Controller: Galil

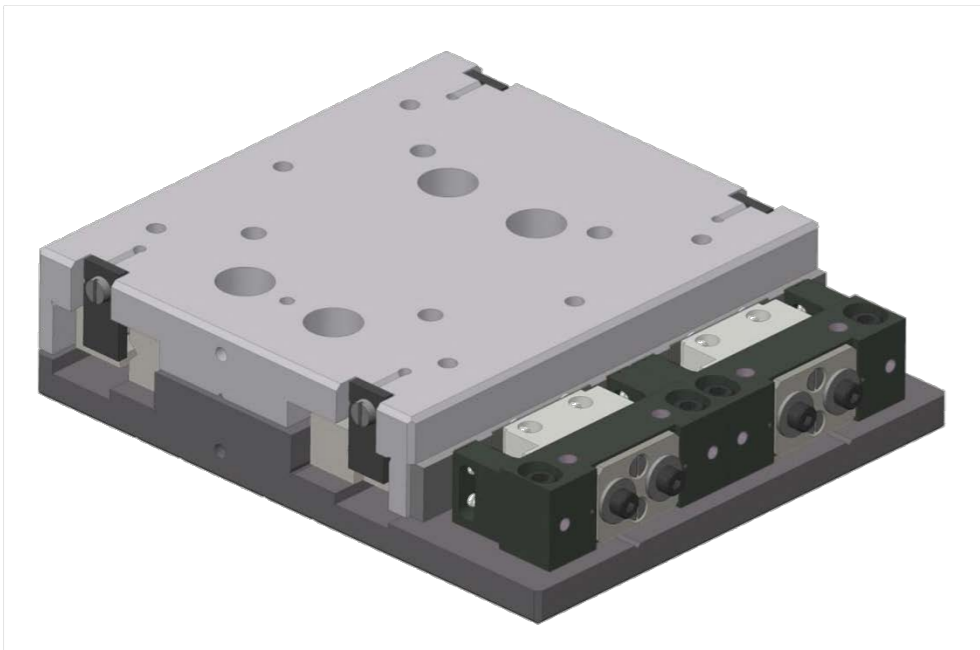



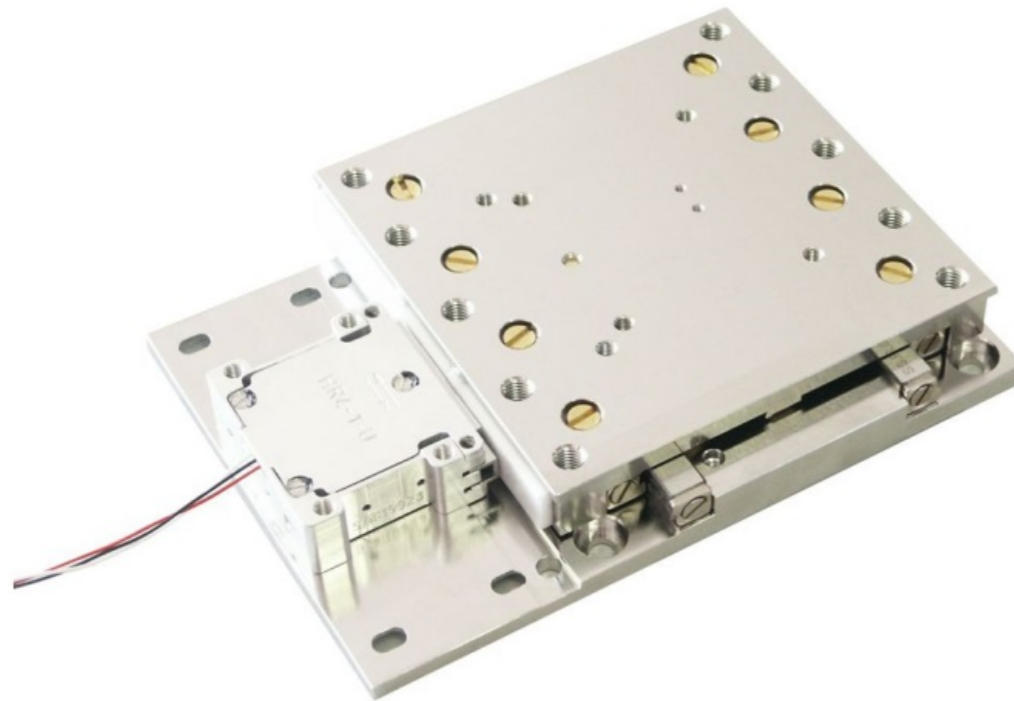

**Application:** multi purpose micro stage

**Benefit:** for high resolution scanning

**Features:** positioning with very high resolution

- Vacuum: all pressure ranges HV / UHV down to  $10^{-11}$  mbar
- Magnetism: magnetic / low magnetic / magnet free
- Lubrication: liquid down to  $10^{-8}$  mbar / dry lube down to  $10^{-11}$  mbar
- max. bake-out temperature: 120 °C

### **Technical Data**

- Stroke: 20 mm, 50 mm
- Repeatability:  $\pm 0,4 \mu\text{m}$  NM,  $\pm 0,1 \mu\text{m}$  PM
- Load: 5 kg horizontally, 0,5 kg vertically
- Velocity: 5 mm/s PM, 50 mm/s NM

### **Components**

- Motor: Piezo Motor / Nanomotion
- Feedback: Linear 5 nm...100 nm
- Guide: Cross Roller Stainless Steel, Hybrid, optionally Ceramics
- Controller: Galil



Mechatronik

## Micro Stage

# MT105ZN-20-NM/PM / MT105ZXL-50-NM/PM

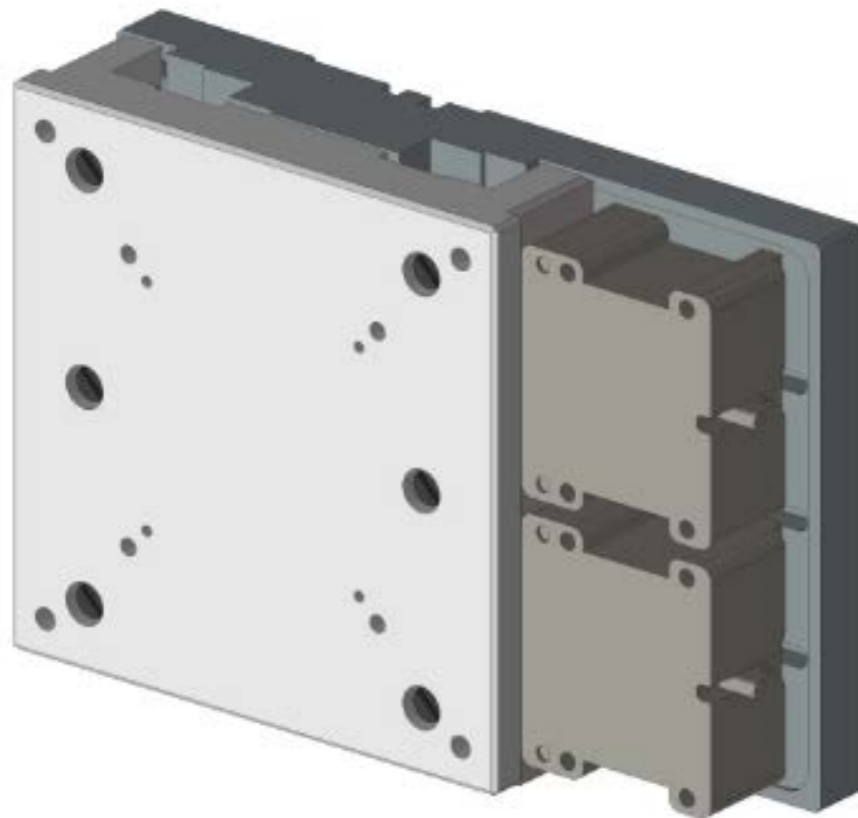

**Application:** multi purpose micro stage for vertical use

**Benefit:** for high resolution scanning

**Features:** positioning with very high resolution

- Vacuum: all pressure ranges HV / UHV down to  $10^{-11}$  mbar
- Magnetism: magnetic / low magnetic / magnet free
- Lubrication: liquid down to  $10^{-8}$  mbar / dry lube down to  $10^{-11}$  mbar
- max. bake-out temperature: 120 °C

### **Technical Data**

- Stroke: 20 mm, 50 mm
- Repeatability:  $\pm 0,4 \mu\text{m}$  NM,  $\pm 0,1 \mu\text{m}$  PM
- Load: 1 kg horizontally, 5 kg vertically (ZXL)
- Velocity: 5 mm/s PM, 50 mm/s NM

### **Components**

- Motor: Piezo Motor / Nanomotion
- Feedback: Linear 5 nm...100 nm
- Guide: Cross Roller Stainless Steel, Hybrid, optionally Ceramics
- Controller: Galil

# Vacuum XY-Stages

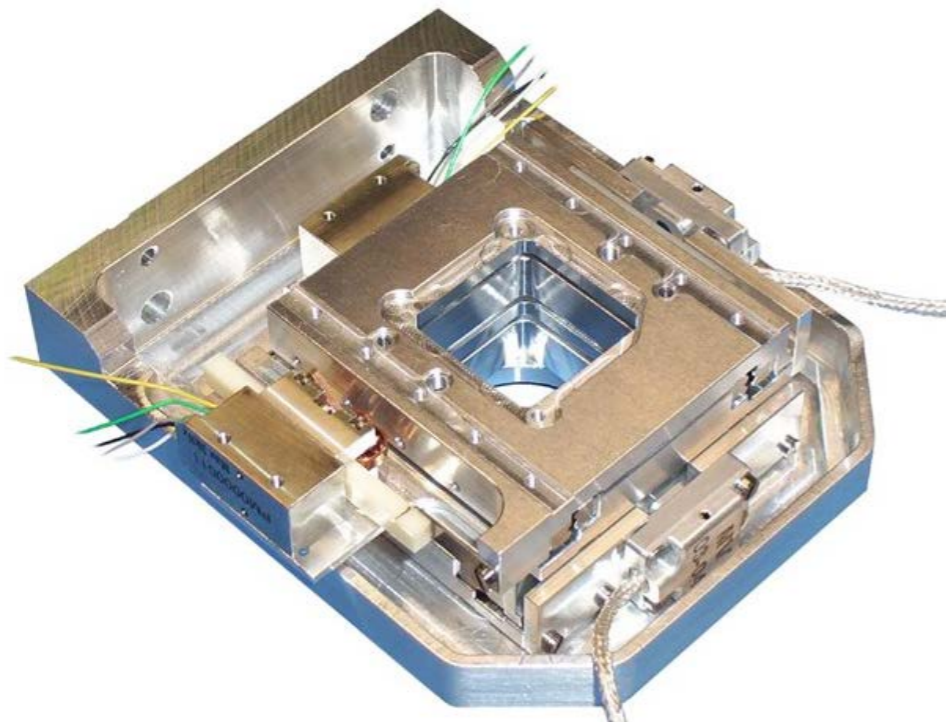

**Application:** sample stage

**Benefit:** high precision XY-stage

**Features:** serial product, very high resolution,  
also available in titanium

- Vacuum: all pressure ranges HV / UHV down to  $10^{-11}$  mbar
- Magnetism: magnetic / low magnetic / magnet free
- Lubrication: liquid down to  $10^{-8}$  mbar / dry lube down to  $10^{-11}$  mbar
- max. bake-out temperature: 120 °C

### **Technical Data**

- Stroke: 20 mm x 20 mm
- Repeatability: 50 nm
- Load: 0,5 kg horizontally
- Velocity: 5 mm/s

### **Components**

- Motor: Piezo Motor
- Feedback: Linear 5 nm...100 nm
- Guide: Cross Roller Stainless Steel, Hybrid, optionally Ceramics
- Controller: Galil

# XY-Stage

## KT105-50-NM/PM / KT180-100-NM/PM

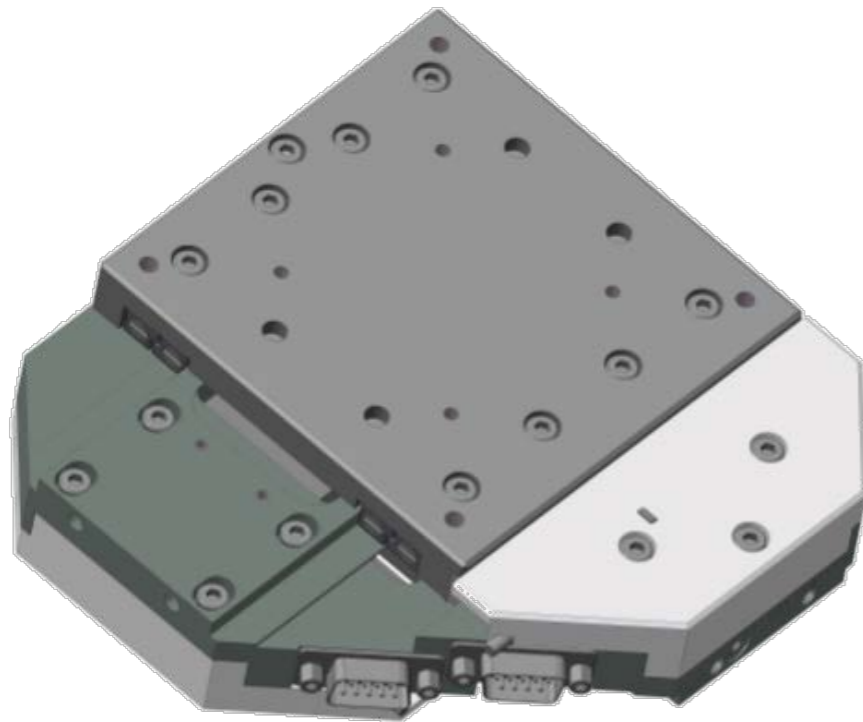

**Application:** vacuum-xy-stage

**Benefit:** fast and high resolution

**Features:** parameters for yaw and pitch three times better than the variant with aperture

- Vacuum: all pressure ranges HV / UHV down to  $10^{-11}$  mbar
- Magnetism: magnetic / low magnetic / magnet free
- Lubrication: liquid lube down to  $10^{-8}$  mbar / dry lube down to  $10^{-11}$  mbar
- max. bake-out temperature: 120 °C

### **Technical Data**

- Stroke: 50 mm, 100 mm
- Repeatability:  $\pm 0,4 \mu\text{m}$  NM,  $\pm 0,1 \mu\text{m}$  PM
- Load: dry lube ca. 1 kg, liquid lube ca. 5 kg horizontally
- Velocity: 5 mm/s PM or 100 mm/s NM

### **Components**

- Motor: Piezo Motor, Nanomotion
- Feedback: Linear 1 nm...100 nm
- Guide: Cross Roller Stainless Steel, Hybrid, optionally Ceramics
- Controller: Galil



Mechatronik

# XY-Stage

## KDT105-50-NM/PM / KDT180-100-NM/PM

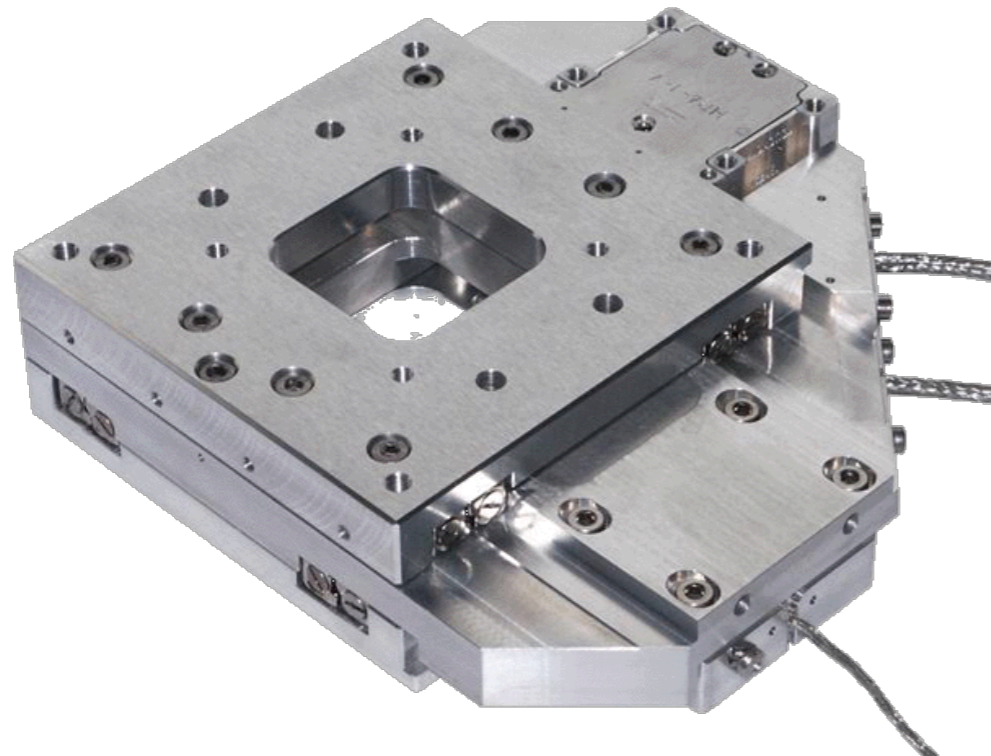

**Application:** vacuum-xy-stage

**Benefit:** fast and high resolution

**Features:** variant with aperture

- Vacuum: all pressure ranges HV / UHV down to  $10^{-11}$  mbar
- Magnetism: magnetic / low magnetic / magnet free
- Lubrication: liquid down to  $10^{-8}$  mbar / dry lube down to  $10^{-11}$  mbar
- max. bake-out temperature: 120 °C

### **Technical Data**

- Stroke: 50 mm
- Repeatability:  $\pm 0,4 \mu\text{m}$  NM,  $\pm 0,1 \mu\text{m}$  PM
- Load: dry lube ca. 1 kg, liquid ca. 3 kg horizontally
- Velocity: 5 mm/s PM or 100 mm/s NM

### **Components**

- Motor: Piezo Motor, Nanomotion
- Feedback: Linear 1 nm...100 nm
- Guide: Cross Roller Stainless Steel, Hybrid, optionally Ceramics
- Controller: Galil

# XY-Stage KLT300-SM (two LT300)

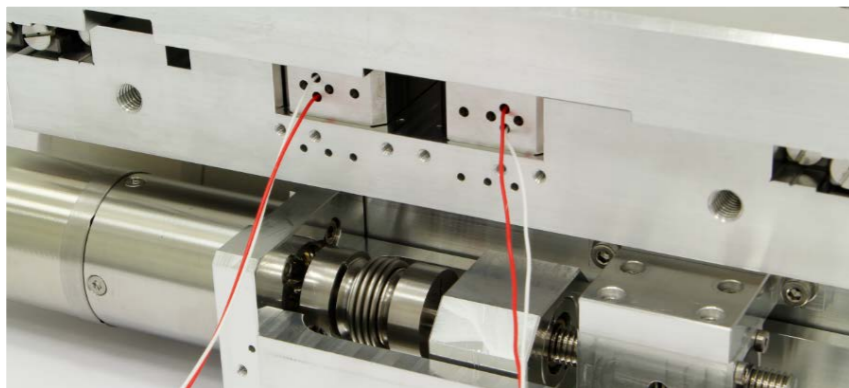

**Application:** transport stage, scanning stage for high loads

**Benefit:** high life time despite dry lube

**Features:** lead screw with dry lube or ball screw with liquid  
piezo brakes for nm-stability

- Vacuum: all pressure ranges HV / UHV down to  $10^{-11}$  mbar
- Magnetism: magnetic
- Lubrication: liquid down to  $10^{-8}$  mbar / dry lube down to  $10^{-11}$  mbar
- max. bake-out temperature: 120 °C

### **Technical Data**

- Stroke: 10 mm, 50 mm, 100 mm
- Repeatability:  $\pm 4 \mu\text{m}$  SM, with Feedback  $\pm 0,5 \mu\text{m}$
- Load: 10 kg horizontally
- Velocity: 5 mm/s

### **Components**

- Motor: Stepper Motor
- Feedback: Open Loop or Linear Scale 100 nm
- Guide: Cross Roller Stainless Steel, Hybrid
- Controller: FMC2, Galil

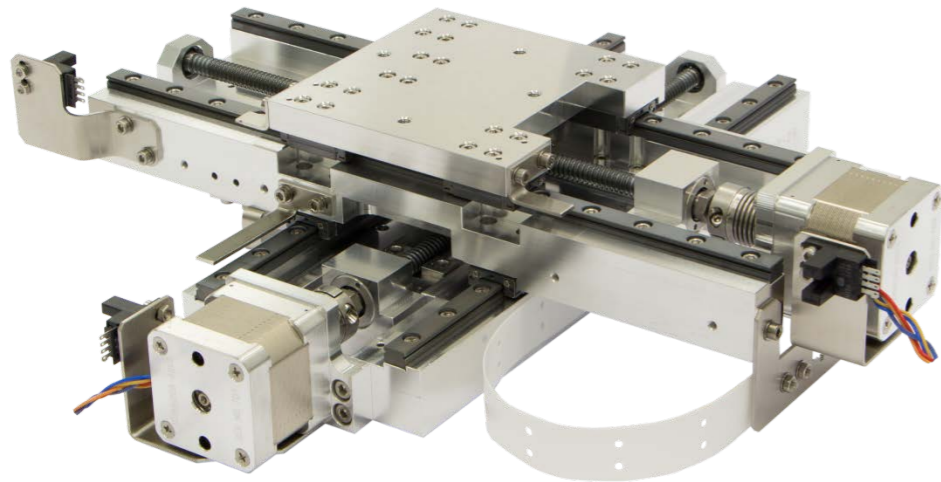

**Application:** compact scanning and transport stage

**Benefit:** small footprint

**Features:** compact height and large stroke

- Vacuum: all pressure ranges HV / UHV down to  $10^{-8}$  mbar
- Magnetism: magnetic
- Lubrication: liquid
- max. bake-out temperature: 100 °C

### **Technical Data**

- Stroke: 100 mm x 150 mm (other lengths on request)
- Repeatability:  $\pm 4 \mu\text{m}$
- Load: 5 kg horizontally
- Velocity: 20 mm/s

### **Components**

- Motor: Stepper Motor
- Feedback: none
- Guide: Stainless Steel-Mini Rail
- Controller: FMC, Galil



# Vacuum Lifting Stages

# Vacuum Lifting Stage HT160-SM

**Application:** vacuum lifting stage

**Benefit:** high stiffness and load

**Features:** wedge with ball screw spindle

- Vacuum: all pressure ranges HV / UHV down to  $10^{-11}$  mbar
- Magnetism: magnetic
- Lubrication: liquid down to  $10^{-8}$  mbar / dry lube down to  $10^{-11}$  mbar
- max. bake-out temperature: 120 °C

## **Technical Data**

- Stroke: 16 mm
- Repeatability:  $\pm 4 \mu\text{m}$  SM, with Feedback  $\pm 1 \mu\text{m}$
- Load: 5 kg vertically
- Velocity: 8,3 mm/s

## **Components**

- Motor: Stepper Motor
- Feedback: none or Linear
- Guide: Cross Roller Stainless Steel, Hybrid
- Controller: Galil

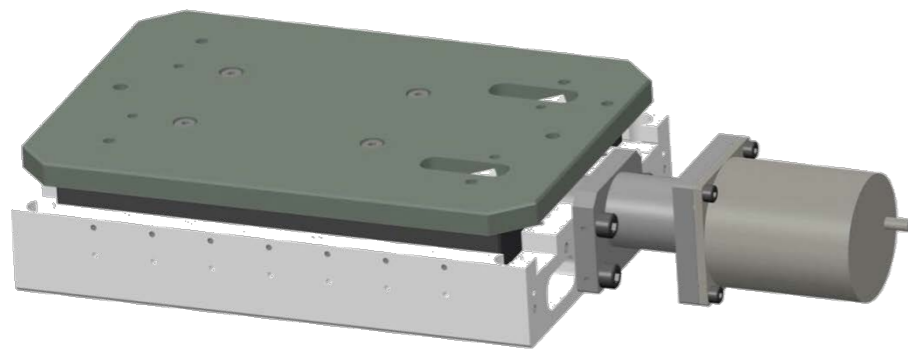

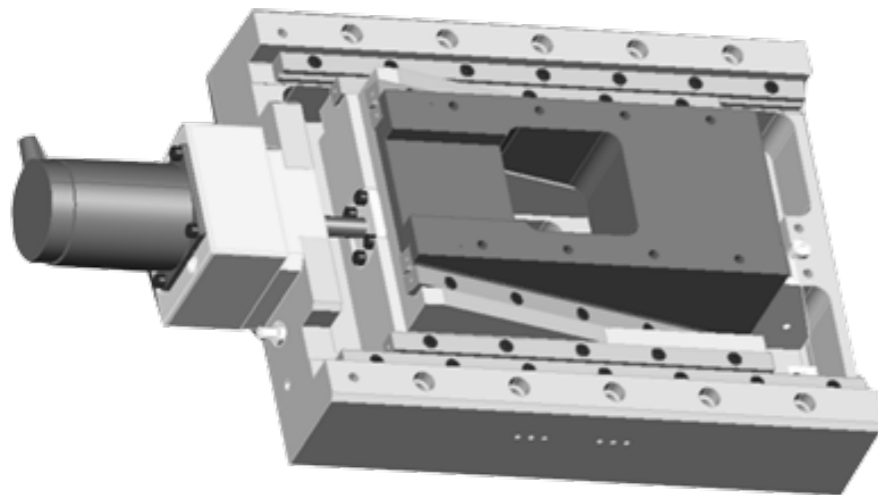
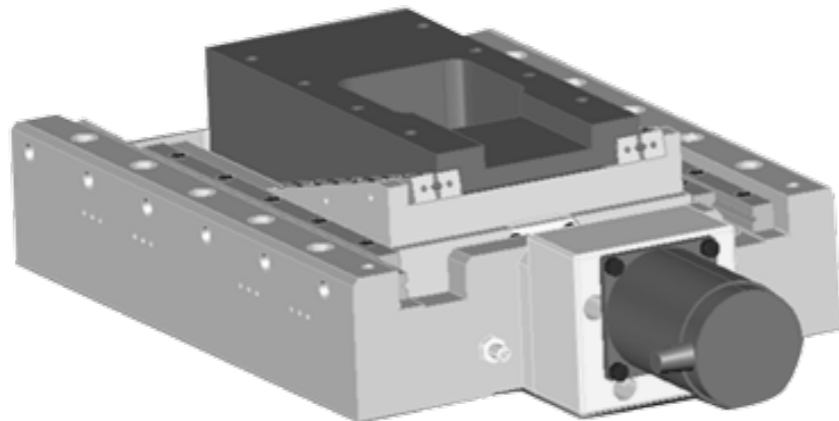

**Application:** vacuum lifting stage

**Benefit:** high stiffness and load, aperture

**Features:** wedge stage with aperture

- Vacuum: all pressure ranges HV / UHV down to  $10^{-11}$  mbar
- Magnetism: magnetic
- Lubrication: liquid down to  $10^{-8}$  mbar / dry lube down to  $10^{-11}$  mbar
- max. bake-out temperature: 120 °C

### **Technical Data**

- Stroke: 16 mm
- Repeatability:  $\pm 4 \mu\text{m}$  SM, with Feedback  $\pm 1 \mu\text{m}$
- Load: 10 kg vertically
- Velocity: 8,3 mm/s

### **Components**

- Motor: Stepper Motor
- Feedback: Open Loop or Linear Scale 100 nm
- Guide: Cross Roller Stainless Steel, Hybrid
- Controller: Galil

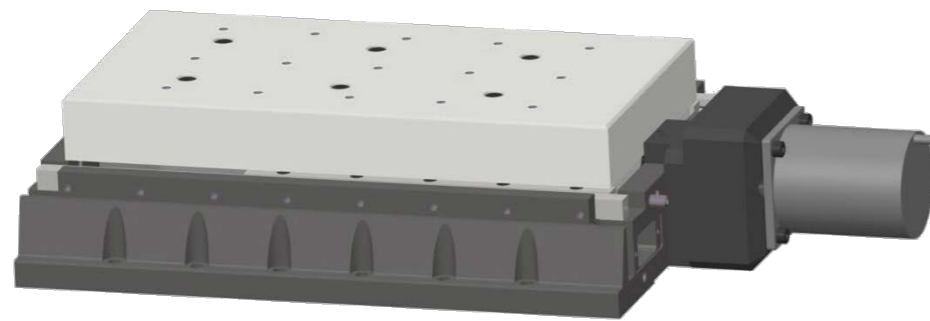

**Application:** vacuum lifting stage

**Benefit:** high stiffness and load

**Features:** wedge with ball screw spindle

- Vacuum: all pressure ranges HV / UHV down to  $10^{-11}$  mbar
- Magnetism: magnetic
- Lubrication: liquid down to  $10^{-8}$  mbar / dry lube down to  $10^{-11}$  mbar
- max. bake-out temperature: 120 °C

### **Technical Data**

- Stroke: 25 mm
- Repeatability:  $\pm 4 \mu\text{m}$  SM, with Feedback  $\pm 1 \mu\text{m}$
- Load: 40 kg vertically
- Velocity: 8,3 mm/s

### **Components**

- Motor: Stepper Motor
- Feedback: Open Loop or Linear Scale 100 nm
- Guide: Cross Roller Stainless Steel, Hybrid
- Controller: Galil

# Vacuum Rotary Stages

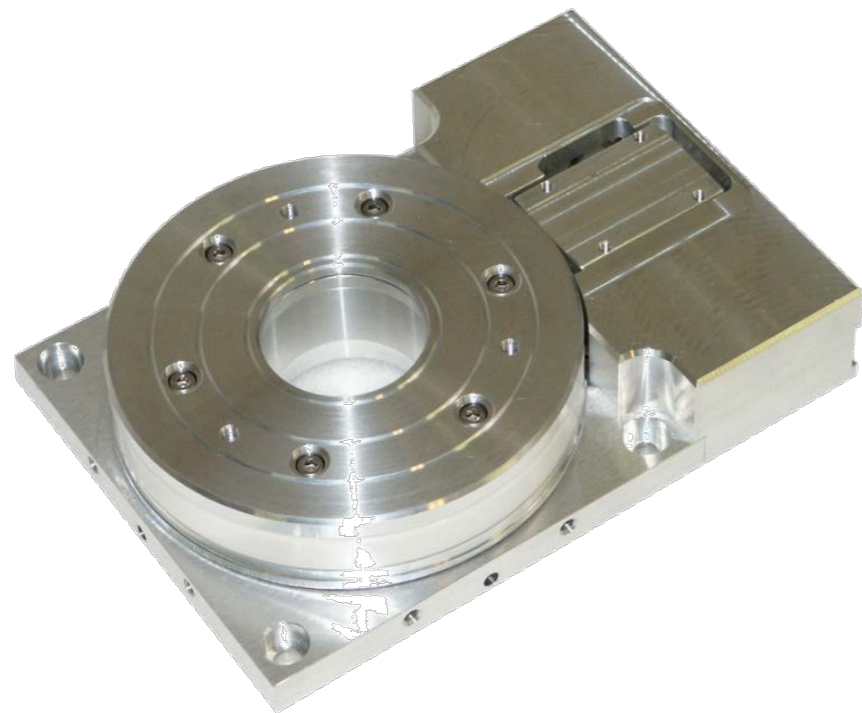

**Application:** Vacuum-Rotary Stage

**Benefit:** for high resolution applications, high speed

**Features:** large aperture, compact height

- Vacuum: all pressure ranges HV / UHV down to  $10^{-11}$  mbar
- Magnetism: magnetic / low magnetic
- Lubrication: liquid down to  $10^{-8}$  mbar
- max. bake-out temperature: 100 °C

#### **Technical Data**

- Rotation: n x 360 deg
- Repeatability: uni  $\pm 0,0005$  deg
- Load: 3 kg
- Velocity: 360 deg/s

#### **Components**

- Motor: Nanomotion
- Feedback: 0,00005 deg
- Guide: Stainless Steel
- Controller: Galil

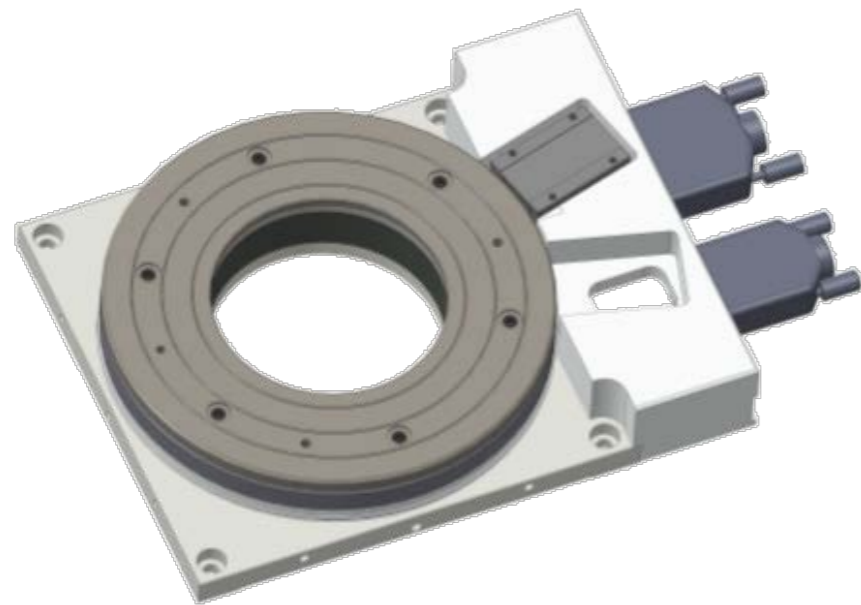

**Application:** Vacuum-Rotary Stage

**Benefit:** for high resolution applications, high speed

**Features:** large aperture, compact height

- Vacuum: all pressure ranges HV / UHV down to  $10^{-11}$  mbar
- Magnetism: magnetic / low magnetic
- Lubrication: liquid down to  $10^{-8}$  mbar
- max. bake-out temperature: 100 °C

### **Technical Data**

- Rotation: n x 360 deg
- Repeatability: uni  $\pm 0,0005$  deg
- Load: 5 kg
- Velocity: 360 deg/s

### **Components**

- Motor: Nanomotion
- Feedback: 0,00005 deg
- Guide: Stainless Steel
- Controller: Galil

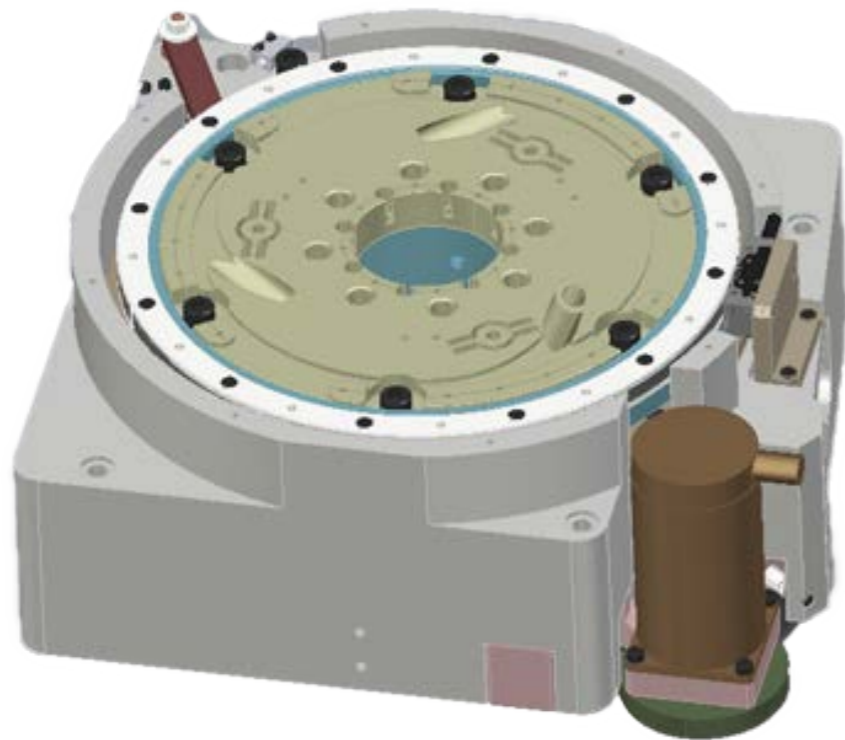

**Application:** Vacuum-Rotary Stage

**Benefit:** for high resolution, high stability

**Features:** aperture, high load

- Vacuum: all pressure ranges HV / UHV down to  $10^{-11}$  mbar
- Magnetism: magnetic / low magnetic / magnet free
- Lubrication: liquid down to  $10^{-8}$  mbar / dry lube down to  $10^{-11}$  mbar
- max. bake-out temperature: 120 °C

### **Technical Data**

- Rotation: n x 360 deg or 370 deg with hard stops
- Repeatability: uni  $\pm 0,0002$  deg
- Load: 15 kg
- Velocity: 90 deg/s

### **Components**

- Motor: Stepper Motor
- Feedback: Resolution 0,00002 deg
- Bearing: Stainless Steel, Hybrid, optionally Ceramics
- Controller: Galil



# Vacuum Manipulators



**Application:** multi purpose manipulator

**Benefit:** for high resolution scanning

**Features:** positioning with very high resolution

- Vacuum: all pressure ranges HV / UHV down to  $10^{-11}$  mbar
- Magnetism: magnetic / low magnetic / magnet free
- Lubrication: liquid down to  $10^{-8}$  mbar / dry lube down to  $10^{-11}$  mbar
- max. bake-out temperature: 120 °C

#### **Technical Data**

- Stroke: 10 mm
- Repeatability: uni  $\pm 0,2 \mu\text{m}$  and bi  $\pm 0,3 \mu\text{m}$
- Load: 0,2 kg
- Velocity: 5 mm/s

#### **Components**

- Motor: Piezo Motor / Nanomotion
- Feedback: Linear 5 nm...100 nm
- Guide: Cross Roller Stainless Steel, Hybrid, optionally Ceramics
- Controller: Galil

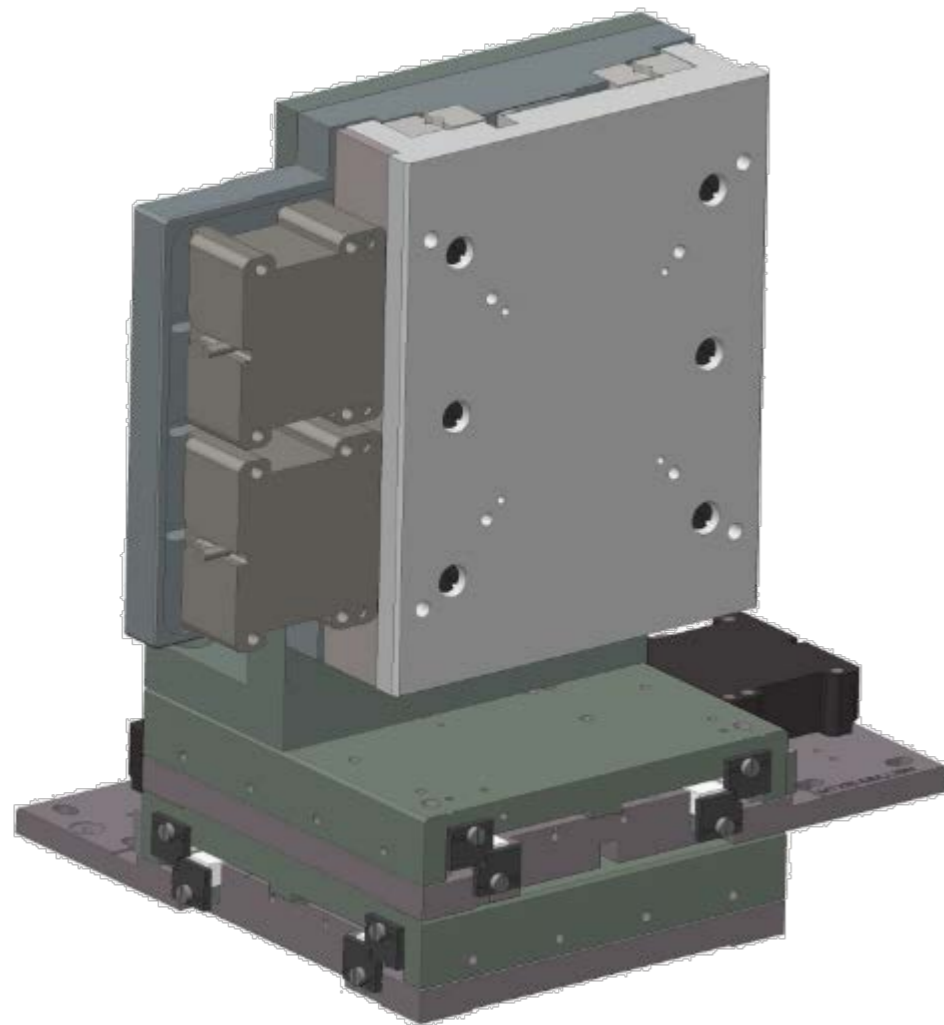

**Application:** multi purpose manipulator

**Benefit:** for high resolution scanning

**Features:** positioning with very high resolution

- Vacuum: all pressure ranges HV / UHV down to  $10^{-11}$  mbar
- Magnetism: magnetic / low magnetic / magnet free
- Lubrication: liquid down to  $10^{-8}$  mbar / dry lube down to  $10^{-11}$  mbar
- max. bake-out temperature: 120 °C

#### **Technical Data**

- Stroke: **XY** 50 mm, **Z** 20 / 50 mm
- Repeatability: uni  $\pm 0,2 \mu\text{m}$  and bi  $\pm 0,3 \mu\text{m}$
- Load: 5 kg
- Velocity: 5 mm/s PM or 100 mm/s NM

#### **Components**

- Motor: Piezo Motor / Nanomotion
- Feedback: Linear 5 nm...100 nm
- Guide: Cross Roller Stainless Steel, Hybrid, optionally Ceramics
- Controller: Galil

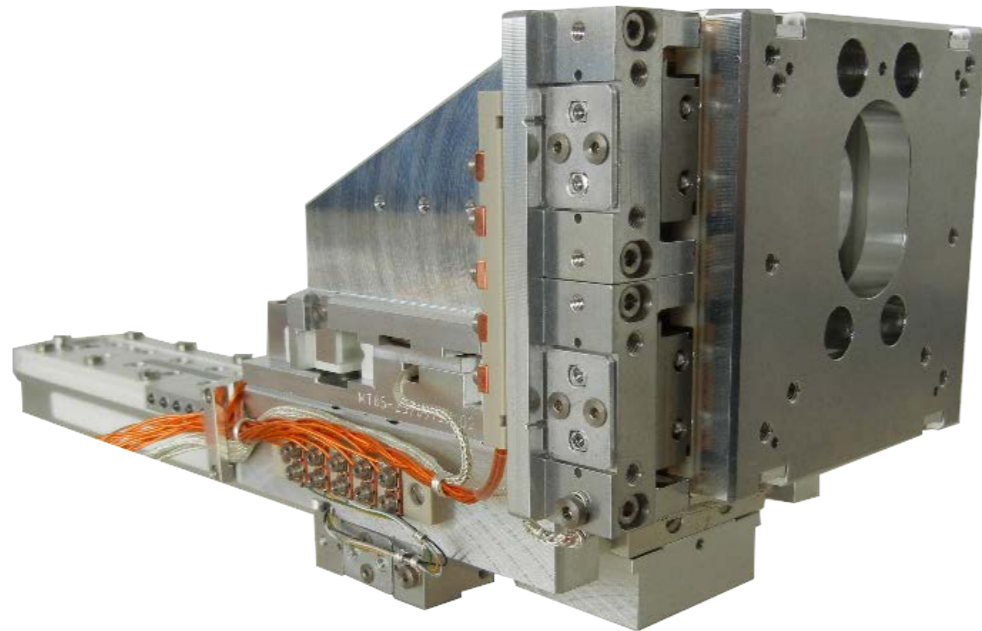

**Application:** multi purpose manipulator

**Benefit:** for high resolution scanning

**Features:** positioning with very high resolution

- Vacuum: all pressure ranges HV / UHV down to  $10^{-11}$  mbar
- Magnetism: magnetic / low magnetic / magnet free
- Lubrication: liquid down to  $10^{-8}$  mbar / dry lube down to  $10^{-11}$  mbar
- max. bake-out temperature: 80 °C

### **Technical Data**

- Stroke: **X** 200 mm / **ZY** 20 mm
- Repeatability: uni  $\pm$  20 nm and bi  $\pm$  30 nm
- Load: 2 kg
- Velocity: 5 mm/s

### **Components**

- Motor: Piezo Motor
- Feedback: Linear 1 nm...100 nm
- Guide: Cross Roller Stainless Steel, Hybrid, optionally Ceramics
- Controller: Galil

# 3-Axis-Manipulator of three LT300

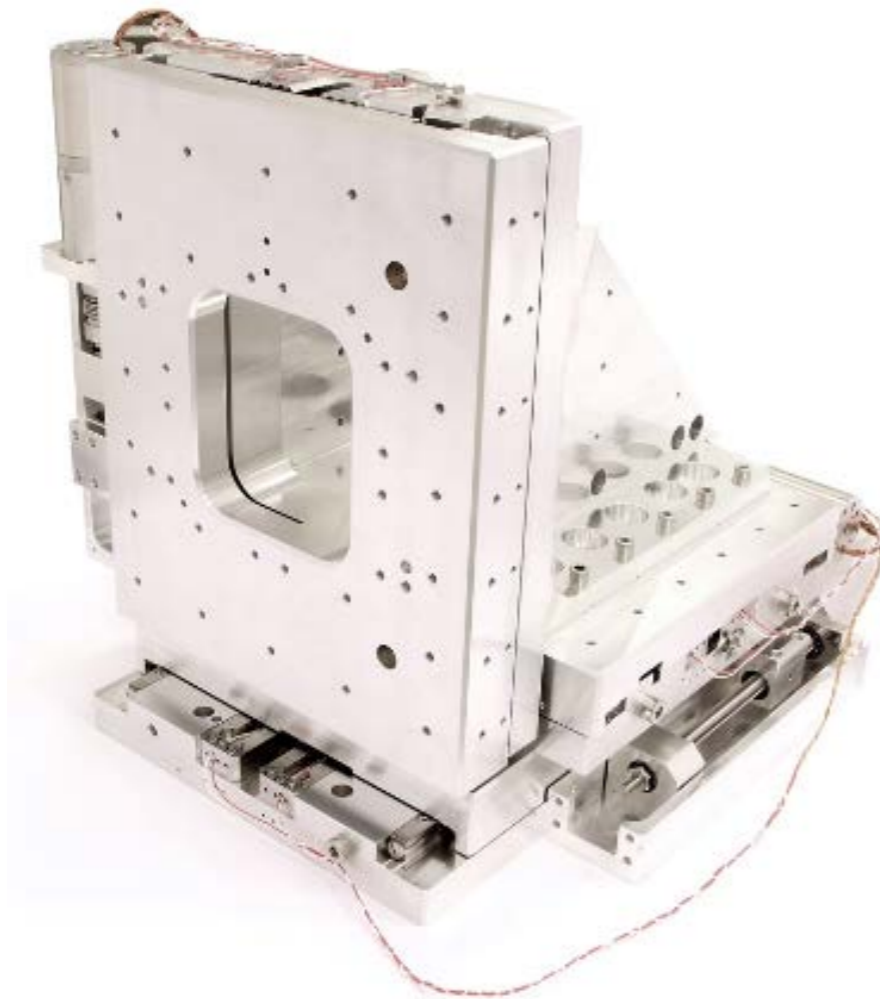

**Application:** HV-3-axis positioning system

**Benefit:** extremely stable upon reaching position,  
dry lube

**Features:** stabilization with piezo brake

- Vacuum: all pressure ranges HV / UHV down to  $10^{-11}$  mbar
- Magnetism: magnetic
- Lubrication: liquid down to  $10^{-8}$  mbar / dry lube down to  $10^{-11}$  mbar
- max. bake-out temperature: 120 °C

### **Technical Data**

- Stroke: 10...100 mm x 10..100 mm x 10..100 mm
- Repeatability:  $\pm 4 \mu\text{m}$  SM, with Feedback  $\pm 0,5 \mu\text{m}$
- Load: 2...5 kg
- Velocity: 5 mm/s

### **Components**

- Motor: Stepper Motor
- Feedback: Open Loop or Linear Scale 1 nm...100 nm
- Guide: Cross Roller Stainless Steel, Hybrid
- Controller: FMC, Galil

# 2-Axis Manipulator of two LA95



**Application:** HV-2-axis positioning system

**Benefit:** extremely stable upon reaching position,  
dry lube

**Features:** stabilization with piezo brake

- Vacuum: all pressure ranges HV / UHV down to  $10^{-11}$  mbar
- Magnetism: magnetic
- Lubrication: liquid down to  $10^{-8}$  mbar / dry lube down to  $10^{-11}$  mbar
- max. bake-out temperature: 120 °C

### **Technical Data**

- Stroke: 7 mm x 7 mm or upon request
- Repeatability:  $\pm 4 \mu\text{m}$  SM, with Feedback  $\pm 0,5 \mu\text{m}$
- Load: 2 kg
- Velocity: 5 mm/s

### **Components**

- Motor: Stepper Motor
- Feedback: Open Loop or Linear Scale 100 nm
- Guide: Cross Roller Stainless Steel, Hybrid
- Controller: FMC, Galil

# 3-Axis Manipulator of three LA95

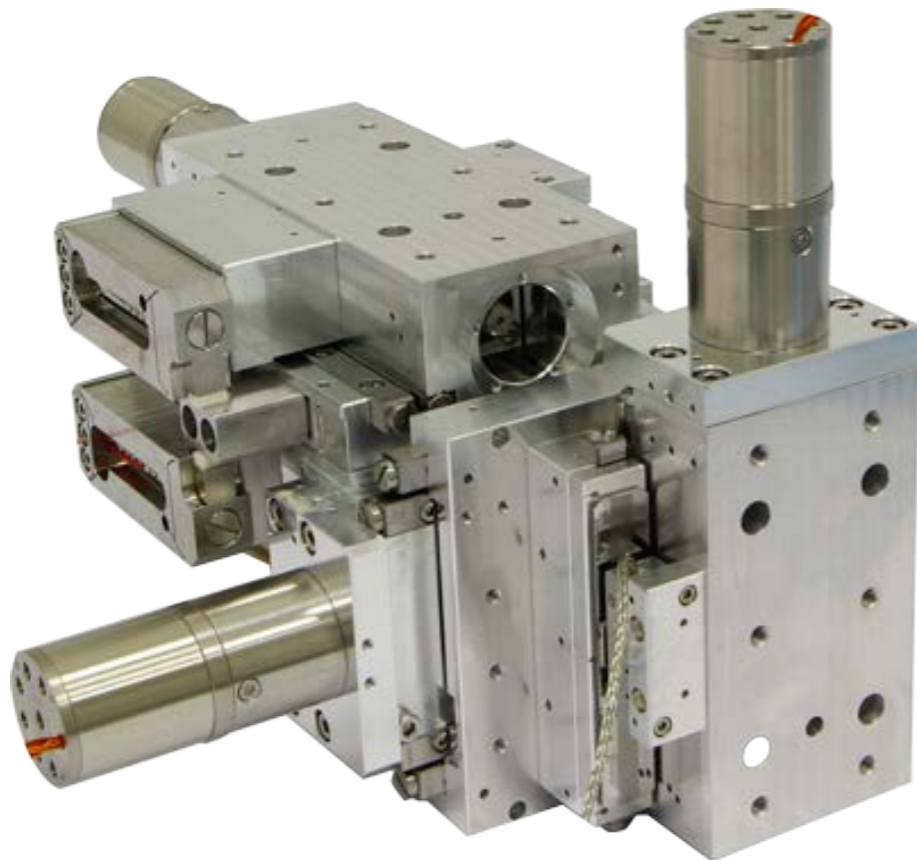

**Application:** HV-3-axis positioning system

**Benefit:** extremely stable upon reaching position,  
dry lube

**Features:** stabilization with piezo brake

- Vacuum: all pressure ranges HV / UHV down to  $10^{-11}$  mbar
- Magnetism: magnetic
- Lubrication: liquid down to  $10^{-8}$  mbar / dry lube down to  $10^{-11}$  mbar
- max. bake-out temperature: 120 °C

### **Technical Data**

- Stroke: 5 mm x 20 mm x 10 mm or upon Request
- Repeatability:  $\pm 4 \mu\text{m}$  SM, with Feedback  $\pm 0,5 \mu\text{m}$
- Load: 2 kg
- Velocity: 5 mm/s

### **Components**

- Motor: Stepper Motor
- Feedback: Open Loop or Linear Scale 100 nm
- Guide: Cross Roller Stainless Steel, Hybrid
- Controller: FMC, Galil

# 3-Axis Manipulator of three LA170

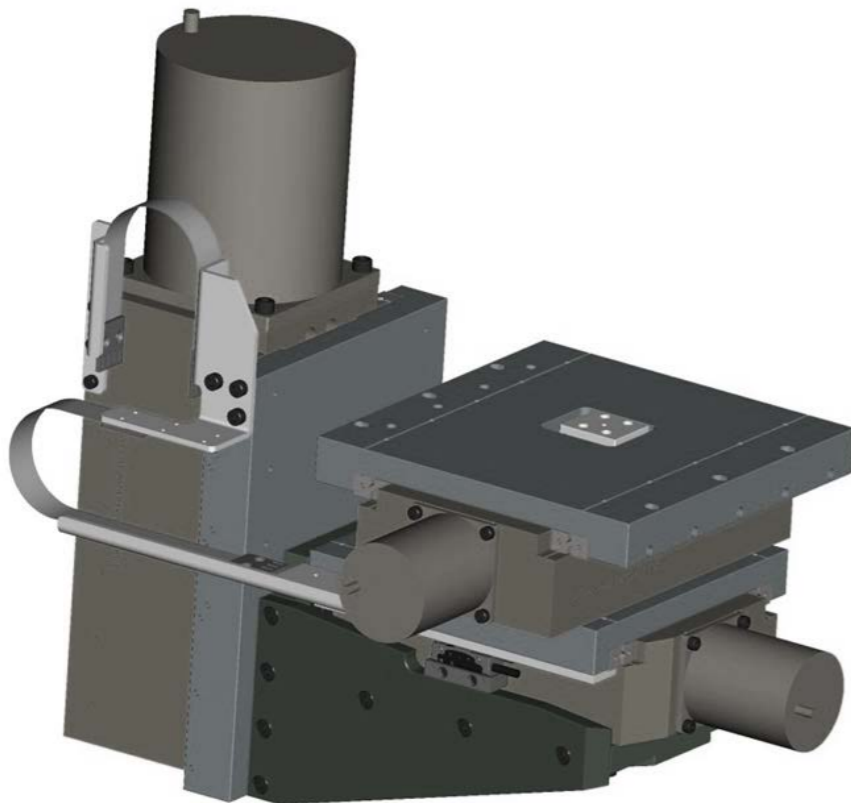

**Application:** HV-3-axis positioning system

**Benefit:** extremely stable upon reaching position,  
dry lube

**Features:** stabilization with piezo brake, high load

- Vacuum: all pressure ranges HV / UHV down to  $10^{-11}$  mbar
- Magnetism: magnetic
- Lubrication: liquid down to  $10^{-8}$  mbar / dry lube down to  $10^{-11}$  mbar
- max. bake-out temperature: 120 °C

### **Technical Data**

- Stroke: 10 mm x 10 mm x 10 mm or upon Request
- Repeatability:  $\pm 4 \mu\text{m}$  SM, with Feedback  $\pm 0,5 \mu\text{m}$
- Load: 20 kg
- Velocity: 5 mm/s

### **Components**

- Motor: Stepper Motor
- Feedback: Open Loop or Linear Scale 100 nm
- Guide: Cross Roller Stainless Steel, Hybrid
- Controller: FMC, Galil



# 3-Axis Manipulator of LA80 and two LA95

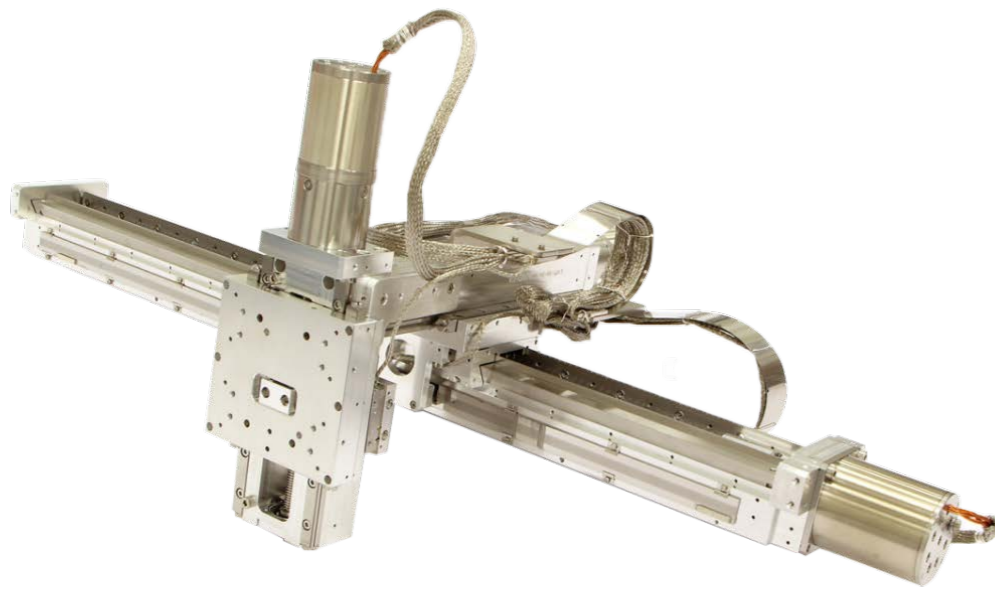

**Application:** HV-3-axis positioning system

**Benefit:** extremely stable upon reaching position,  
dry lube

**Features:** high speed transfer axes

- Vacuum: all pressure ranges HV / UHV down to  $10^{-11}$  mbar
- Magnetism: magnetic
- Lubrication: liquid down to  $10^{-8}$  mbar / dry lube down to  $10^{-11}$  mbar
- max. bake-out temperature: 120 °C

### **Technical Data**

- Stroke: 200 mm x 20 mm x 20 mm
- Repeatability:  $\pm 4 \mu\text{m}$  SM, with Feedback  $\pm 0,5 \mu\text{m}$
- Load: 2 kg
- Velocity: 5 mm/s respectively 100 mm/s

### **Components**

- Motor: Stepper Motor
- Feedback: Open Loop or Linear Scale 100 nm
- Guide: Cross Roller Hybrid respectively recirculating Ball Guides
- Controller: Galil

## Examples of Vacuum Systems

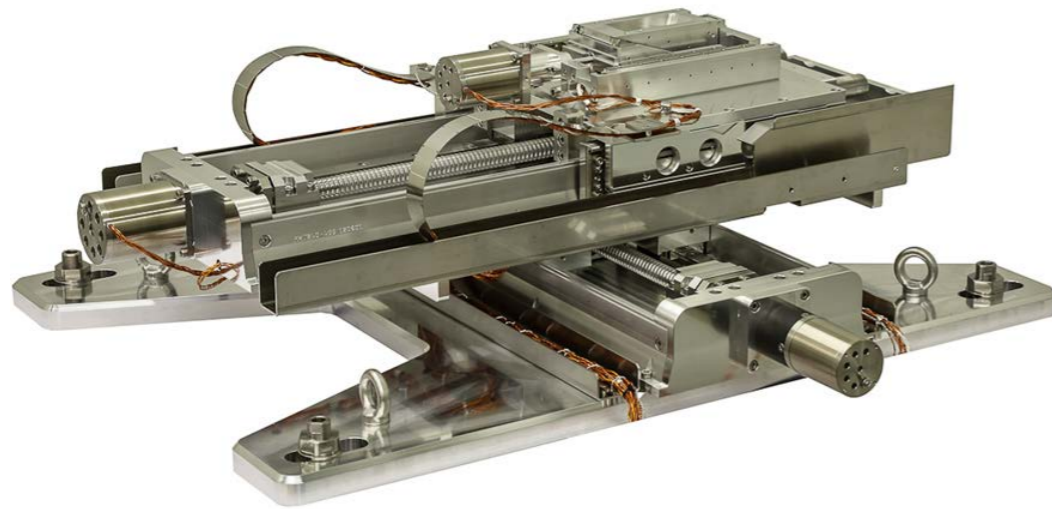

**Application:** investigation of mineral samples

**Stages:** X PLT240-SM, Y PLT240-SM, Z HT160-SM

**Features:** positioning of high loads in vacuum

- Vacuum:  $10^{-6}$  mbar
- Magnetism: magnetic
- Lubrication: liquid
- max. bake-out temperature: 80 °C

### **Technical Data**

- Stroke: 200 mm x 200 mm x 16 mm
- Repeatability:  $\pm 4 \mu\text{m}$
- Load: 20 kg

### **Components**

- Motor: Stepper Motor
- Feedback: none
- Guide: Cross Roller Hybrid, Stainless Steel Mini Rail
- Controller: Galil

# 4-Achs XYZ $\theta$ Sample Manipulator

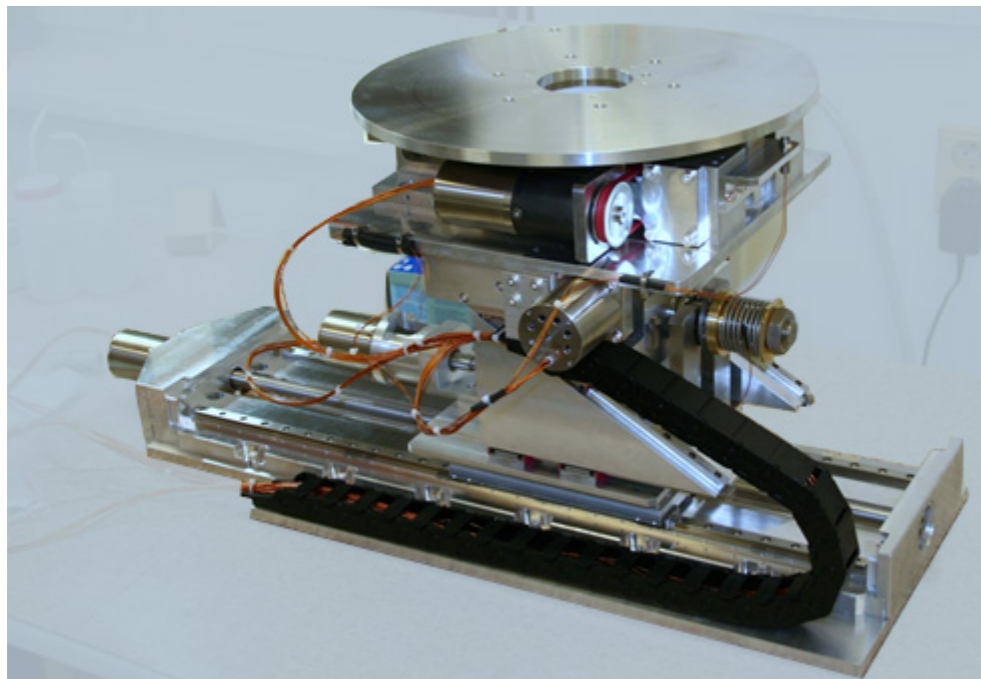

**Application:** measuring material samples

**Stages:** PLT240-SM, HT160-SM, PMT160-SM, DT310-SM

**Features:** vacuum tested belt drive

- Vacuum:  $10^{-6}$  mbar
- Magnetism: magnetic
- Lubrication: liquid
- max. bake-out temperature: 80 °C

## **Technical Data**

- Stroke: 300 mm x 16 mm x 50 mm and Rotation
- Repeatability:  $\pm 4 \mu\text{m}$
- Load: 5 kg

## **Components**

- Motor: Stepper Motor
- Feedback: none
- Guide: Cross Roller Hybrid, Stainless Steel Mini Rail
- Controller: Galil

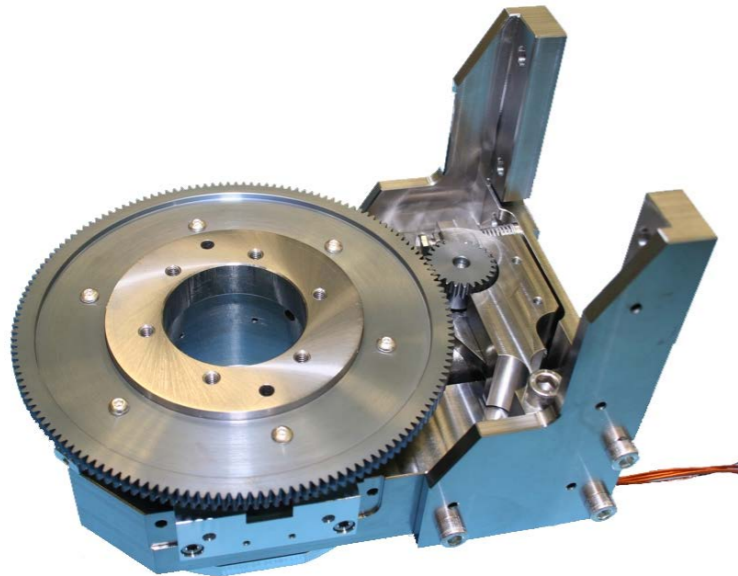
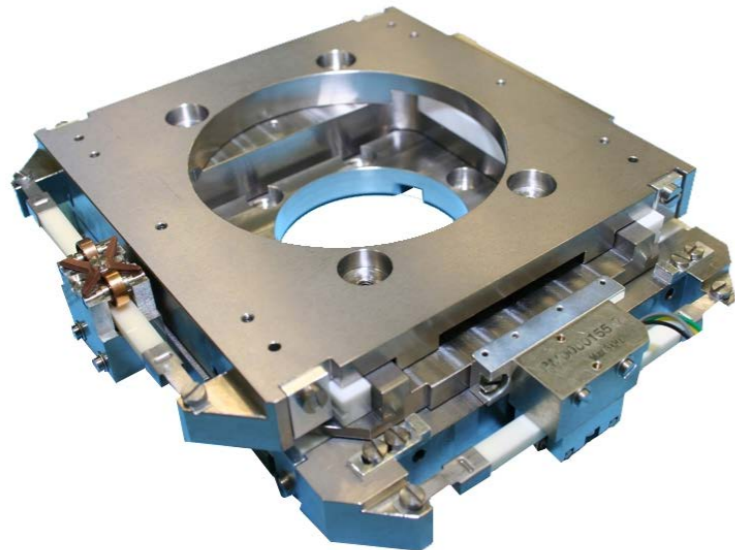

**Application:** sample translation and rotation

**Stages:** custom-KDT, custom-DT

**Features:** XY-Stages from titanium

- Vacuum:  $10^{-11}$  mbar
- Magnetism: center components completely non-magnetic
- Lubrication: none
- max. bake-out temperature: 120 °C

### **Technical Data**

- Stroke: 20 mm x 20 mm x 50 mm and Rotation
- Repeatability:  $\pm 0,1 \mu\text{m}$
- Load: 0,2 kg

### **Components**

- Motor: Piezo Motor, Stepper Motor
- Feedback: Linear 1 nm
- Guide: Cross Roller and Bearing Ceramics, Stainless Steel Mini Rail
- Controller: Galil

**Application:** machining with ion-beam

**Stages:** custom DT, custom DT,  
custom linear stage

**Features:** two co-axial rotary stages with common linear

- Vacuum:  $10^{-8}$  mbar
- Magnetism: non-magnetic
- Lubrication: minimal liquid
- max. bake-out temperature: 120 °C

### **Technical Data**

- Stroke: 50 mm, Rotation, Rotation
- Repeatability:  $\pm 0,1 \mu\text{m}$
- Load: 0,25 kg

### **Components**

- Motor: Nanomotion
- Feedback: Angle, Linear 5 nm
- Guide: Bearing Ceramics
- Controller: Galil

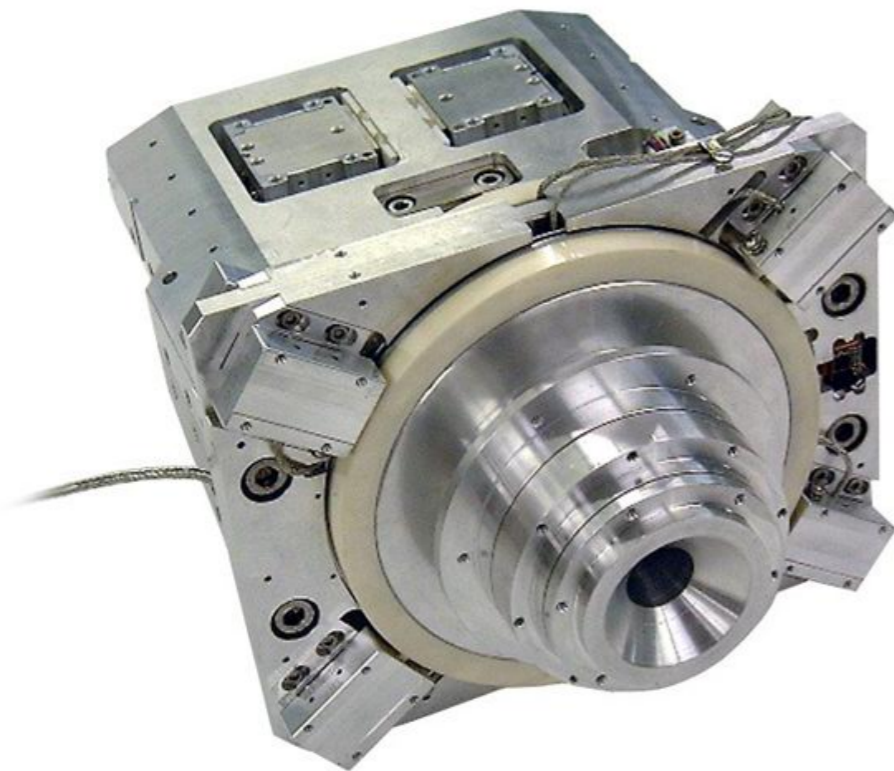

# 4+1-Axis Camera Manipulator

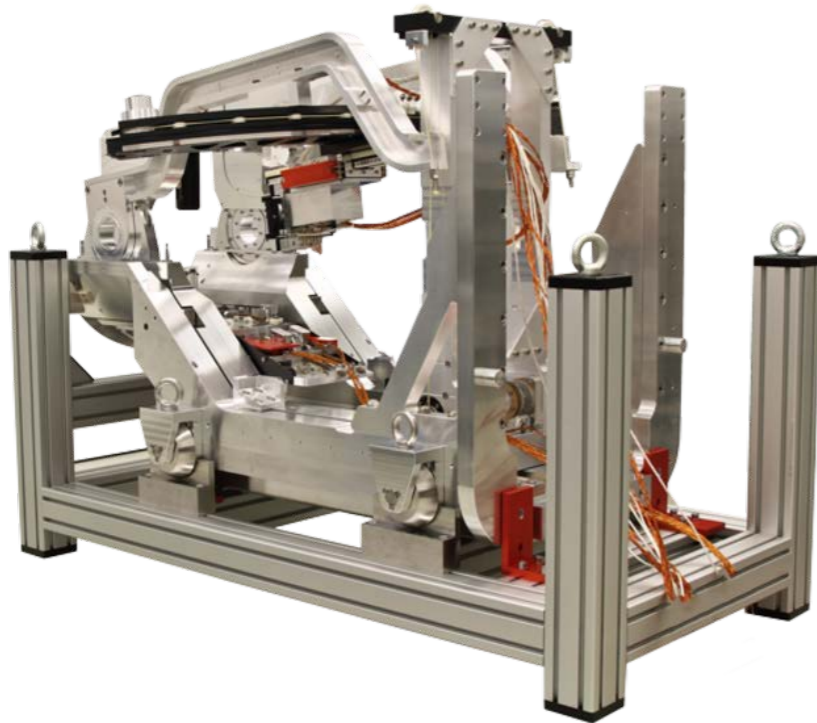
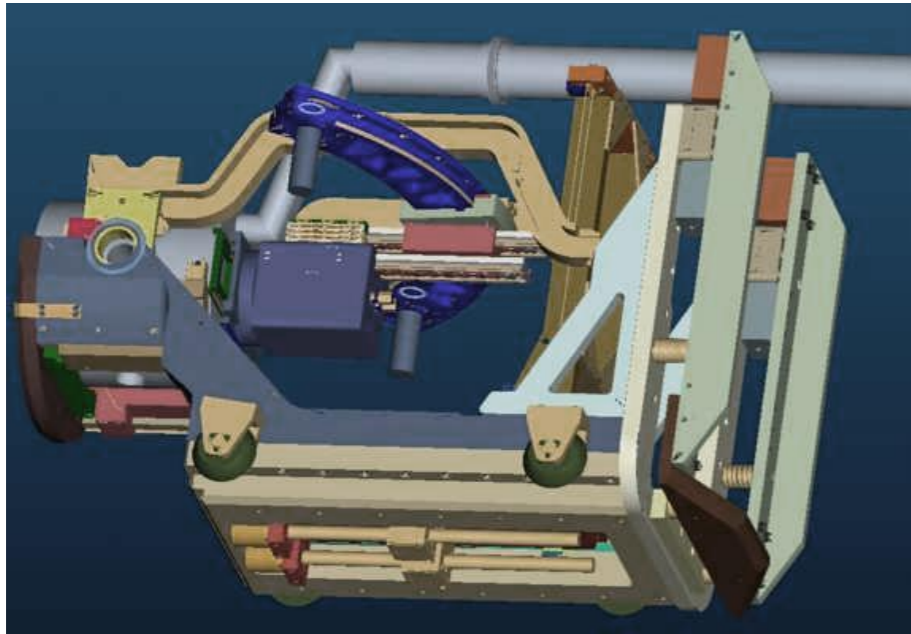

**Application:** 3D motion of an X-Ray camera

**Stages:** custom swivel horizontally  
 custom swivel vertically  
 custom linear stage A-Drive  
 custom linear stage for filters  
 global transfer with ball screw drive

**Features:** withstands strong magnetic scatter field  
 in center of manipulator

- Vacuum:  $10^{-8}$  mbar
- Magnetism: nonmagnetic in center
- Lubrication: dry lube, minimal liquid
- max. bake-out temperature: 80 °C

### Technical Data

- Stroke:  $\pm 30$ ,  $\pm 40$ , 300 mm, 100 mm, 350 mm
- Repeatability:  $\pm 1 \mu\text{m}$
- Load: 8 kg (120 kg for global transfer)

### Components

- Motor: Piezo Motor, Stepper Motor
- Feedback: Linear 100 nm
- Guide: Bearing Ceramics
- Controller: Galil

# 6-Achs Sample Manipulator (RICS-Experiment)

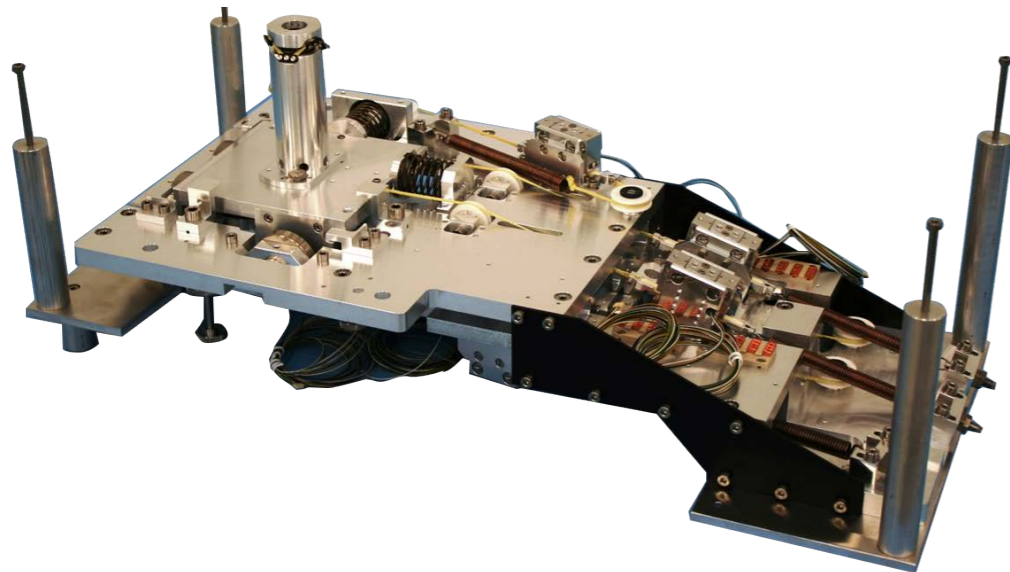

**Application:**  $\mu\text{m}$  and  $\text{nm}$  manipulation of samples

**Stages:** custom design of cartesian 6 dof manipulator

**Features:** ropes in vacuum, magnet free, capacitive sensors

- Vacuum:  $10^{-8}$  mbar
- Magnetism: non-magnetic
- Lubrication: dry lube
- max. bake-out temperature:  $80\text{ }^{\circ}\text{C}$

## **Technical Data**

- Stroke: translation  $\text{XYZ} \pm 3\text{ mm}$ , rotational  $\text{XYZ} \pm 1^{\circ}$
- Repeatability:  $\pm 0,05\ \mu\text{m}$
- Load:  $0,05\text{ kg}$

## **Components**

- Motor: Piezo Motor, Ropes
- Feedback:  $0,1\text{ nm}$  capacitive
- Guide: Ropes
- Controller: Galil



# 6-Achs Sample Manipulator (RICS-Experiment)

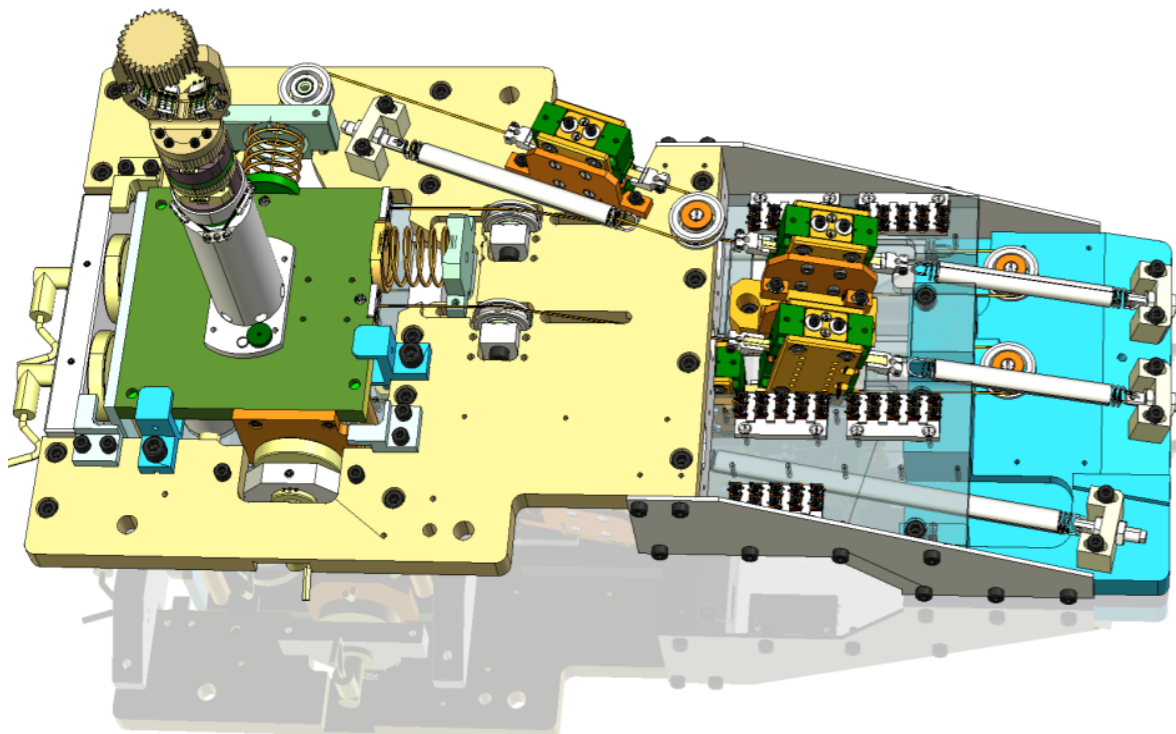

Sample Manipulator from Above

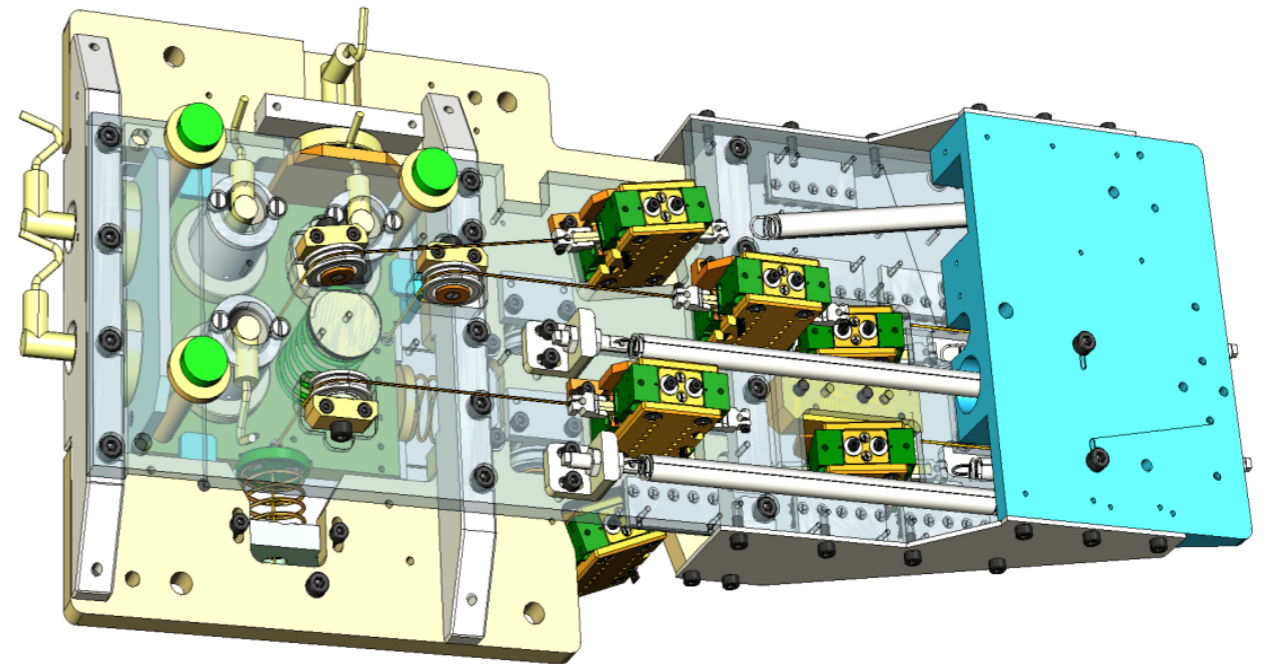

Sample Manipulator from Below



**Application:** adjusting position in a coating process

**Stages:** LPT60-SM, LPT60-SM, custom manual drive

**Features:** based on HV-versions of catalogue stages

- Vacuum:  $10^{-6}$  mbar
- Magnetism: magnetic
- Lubrication: liquid
- max. bake-out temperature: 80 °C

### **Technical Data**

- Stroke: 100 mm, 100 mm, 150 mm
- Repeatability:  $\pm 4 \mu\text{m}$
- Load: 5 kg

### **Components**

- Motor: Stepper Motor
- Feedback: none
- Guide: Mini Rail Stainless Steel
- Controller: Galil

# 4 Axis Sample Manipulator

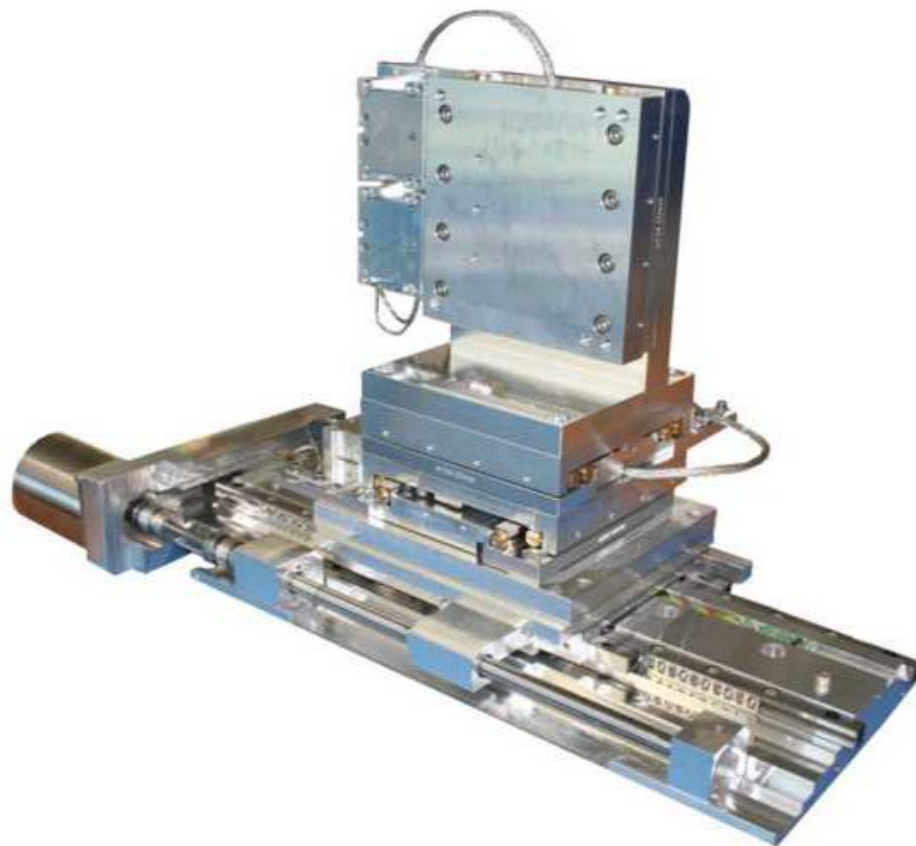

**Application:** sample translation

**Stages:** PMT160-SM, MT105-NM, MT105-NM, MT105-2NM

**Features:** coarse positioning with ball screw,  
fine positioning with Nanomotion

- Vacuum:  $10^{-8}$  mbar
- Magnetism: magnetic
- Lubrication: liquid
- max. bake-out temperature: 100 °C

## **Technical Data**

- Stroke: 100 mm and 50 mm x 50 mm x 20 mm
- Repeatability:  $\pm 0,1 \mu\text{m}$
- Load: 0,25 kg

## **Components**

- Motor: Nanomotion, Stepper Motor
- Feedback: none, Linear 5 nm
- Guide: Cross Roller
- Controller: Galil

## Accessories and Features

# Piezo Brake Enhances Stability

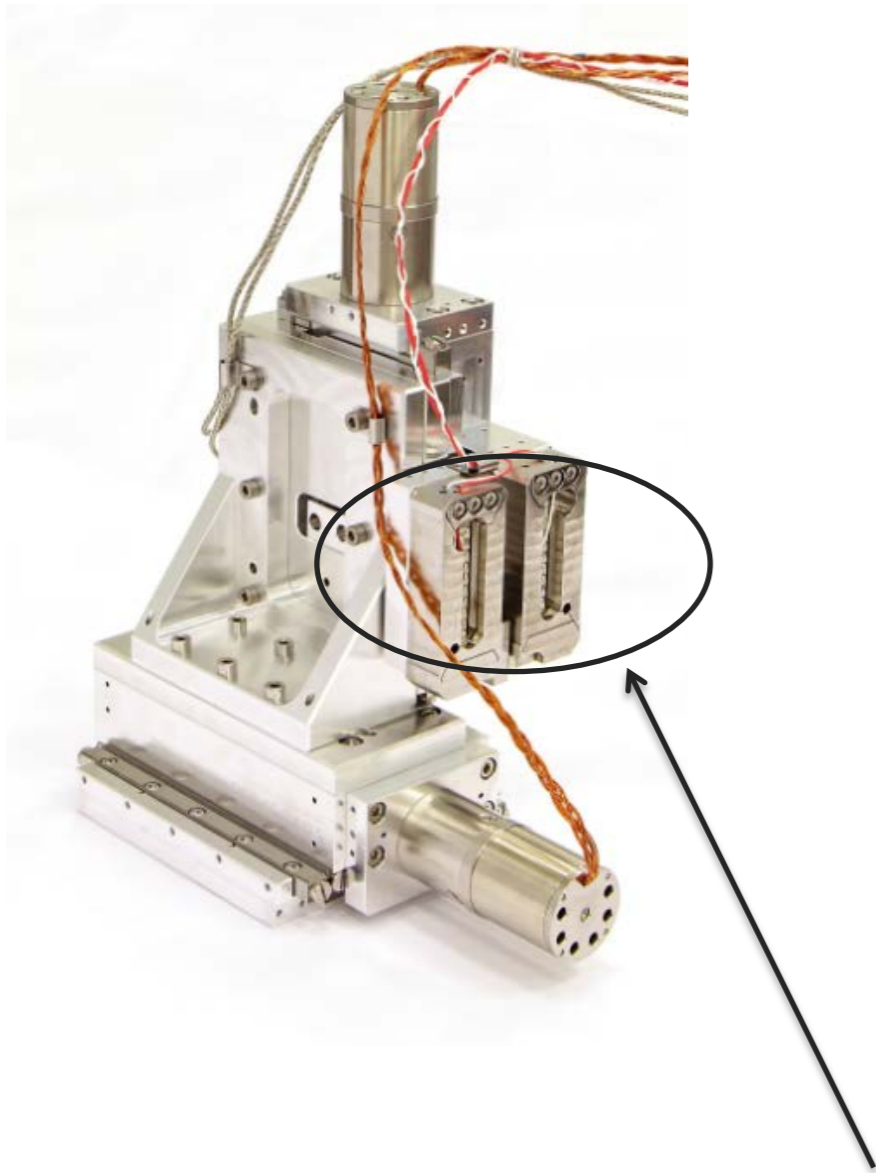

Upon reaching position the piezo brake engages and boosts stiffness. In result, light structures can be made extremely stiff.

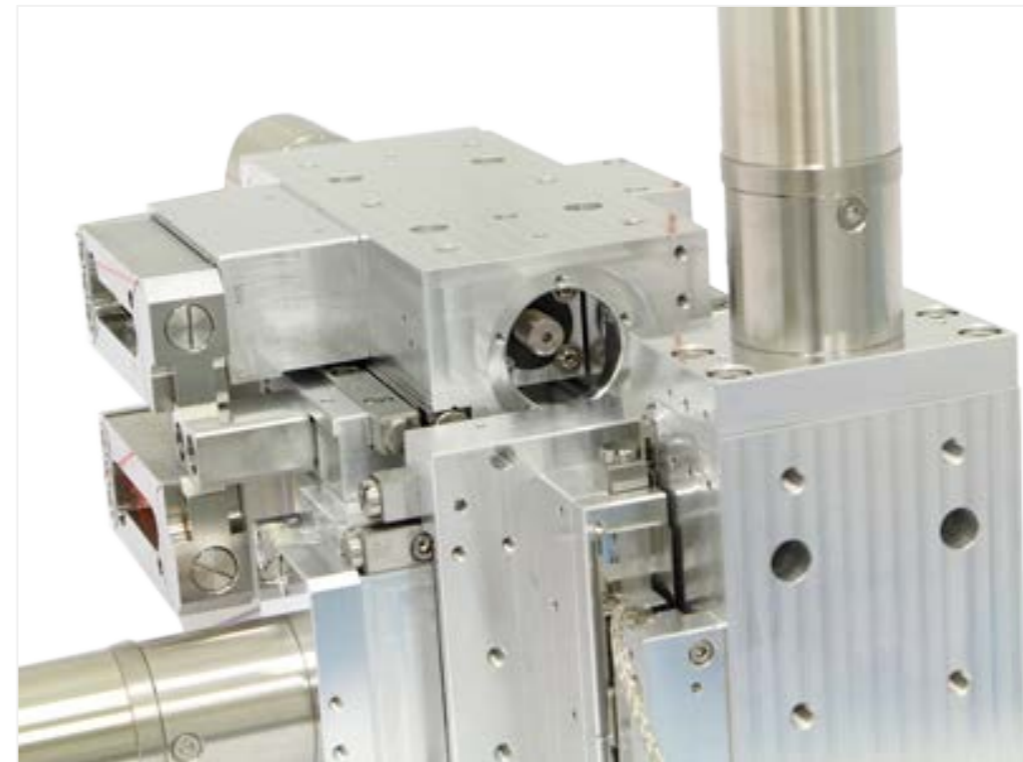
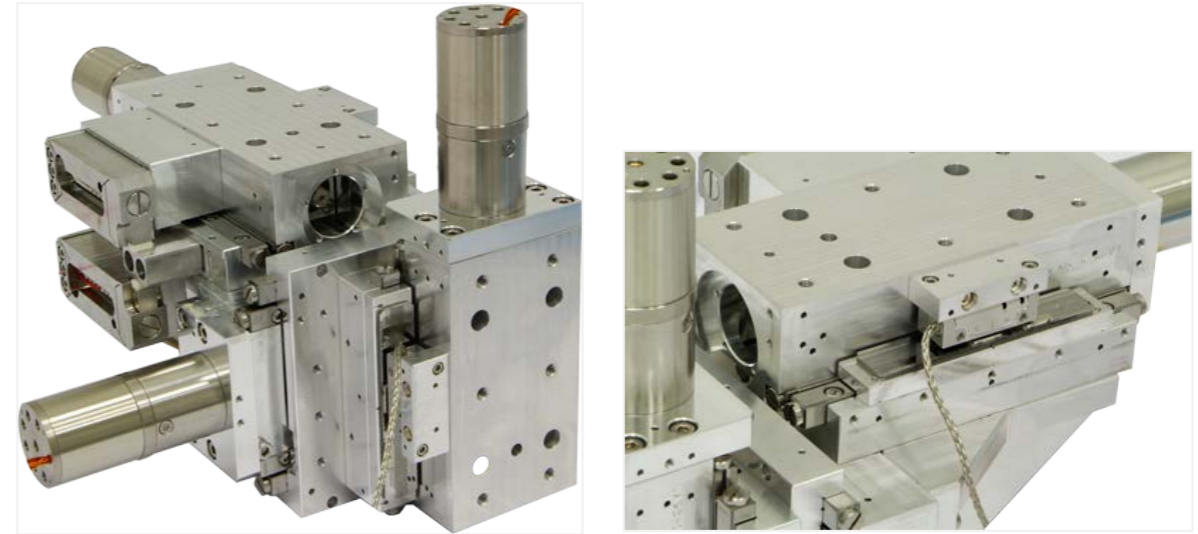





Mechatronik

# Vacuum Stages Based on Atmospheric Standard Catalogue Stages

# Stages with Available Vacuum Preparation

The stages listed hereafter are available in HV-Vacuum preparation.

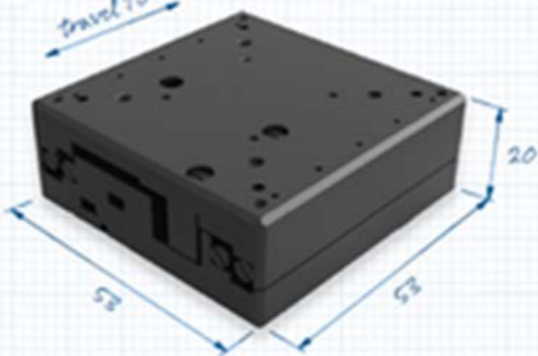
- Liquid lubrication for pressures down to  $10^{-8}$  mbar
- Maximum bake-out temperature 80°C
- Fitted with Phytron stepper motors
- Stainless steel components (bearings, guides, ball screw)
- Kapton or PTFE cabling
- Kapton or Ceramic Sub-D plug
- Machined aluminum without anodization,
- Vacuum cleaned
- Venting holes, split washers or screws with bore
- Without covers (unlike some shown)
- Assembled in our clean room
- End-cleaned
- Delivered in sealed double plastic bag

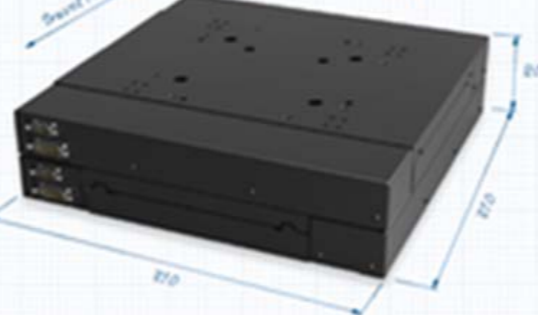
	<p>MT53-SM</p>
	<p>MT130-SM</p>
	<p>KLT310-SM</p>
	<p>KLT310-SM</p>

# Stages with Available Vacuum Preparation

	<p>LA85-SM</p>		<p>PMT160-SM</p>
	<p>LTP30-SM</p>		<p>PLT165-SM</p>
	<p>LTP60-SM</p>		<p>PLT240-SM</p>
	<p>LTP80-SM</p>		<p>PLT320-SM</p>





## **Steinmeyer Mechatronik**

Fritz-Schreiter-Straße 32

01259 Dresden

+49 351 88585-0

[mechatronik@steinmeyer.com](mailto:mechatronik@steinmeyer.com)

[www.steinmeyer-mechatronik.de](http://www.steinmeyer-mechatronik.de)